



Spray Nozzle Basics

Spray Nozzle Precision Guarantee

All IKEUCHI's precision-made hydraulic spray nozzles are guaranteed for spray capacity and spray angle.

This guarantee covers metal, plastic, and ceramic nozzles.

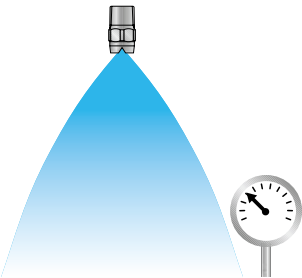
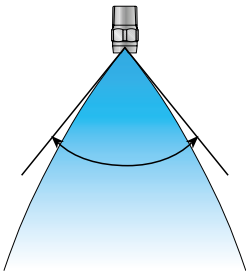
We also set our own inspection standard for spray pattern and only the nozzles that pass the inspection will be shipped.

Spray Capacity Tolerance	Spray Angle Tolerance	Spray Angle Tolerance for Solid Stream Nozzles
		
<p>+/-5%</p>	<p>+/-5°</p>	<p>Within 3°</p>
<p>The spray nozzles shown in this catalog are guaranteed within +/-5% of the rated spray capacity under standard pressure.</p>	<p>The flat and cone shaped spray nozzles shown in this catalog are guaranteed within +/-5° of the rated spray angle under standard pressure. The spray angle gives the angle of the spray measured near the nozzle, unless otherwise specified.</p>	<p>The solid stream jet nozzles shown in this catalog are guaranteed for the axis of spray direction to be within 3° from the nozzle body centerline under standard pressure.</p>
<p>[Note] This guarantee does not cover air nozzles. The air consumption, or volume of blown air, shown in this catalog is for reference only.</p>		

Fog Classification System

This classification is based on the spray droplet size, by measuring the spray droplet diameter with the immersion sampling method.

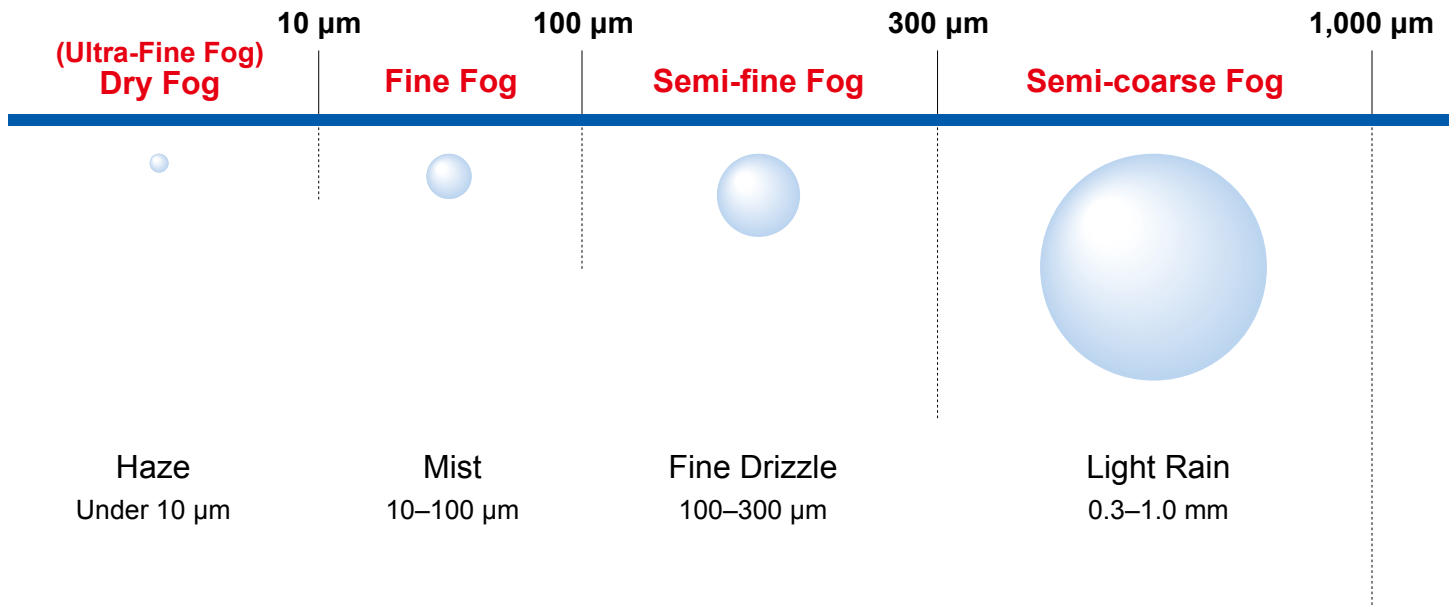



Spray Pattern and Distribution

Standard pressure, or design pressure, is defined as the most commonly used liquid pressure for each hydraulic spray nozzle series. Our nozzles are designed to provide the specified spray capacity, spray angle, optimal spray pattern, and spray distribution at each standard pressure.

The values in this catalog are based on tap water at room temperature and the liquid pressure is measured right at the nozzle.

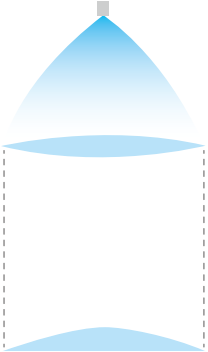
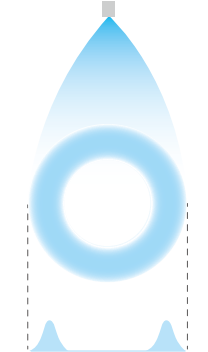
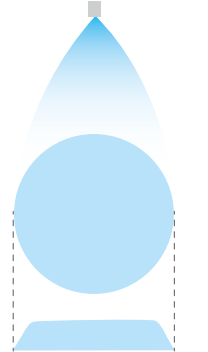
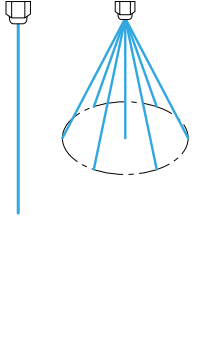
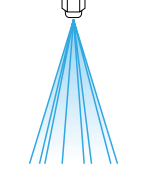
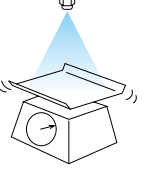
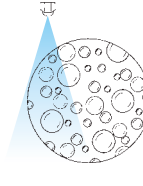
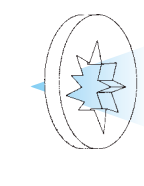
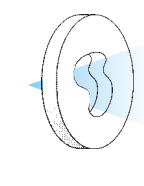
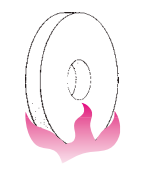
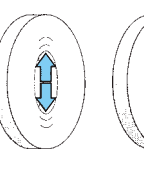
For details please see the technical references at the end of this catalog.

<p>Spray Pattern</p> <p>Spray pattern is defined as the horizontal cross sectional shape of the spray.</p>	<p>Flat Spray</p>  <p>Mountain-shaped distribution</p>	<p>Hollow Cone Spray</p>  <p>Ring-shaped distribution</p>	<p>Full Cone Spray</p>  <p>Even spray distribution</p>	<p>Solid Stream Spray</p> 				
<p>Spray Distribution</p> <p>Spray distribution is defined as the distribution of the spray flow in the direction of spray width.</p>								
<p>Other Factors</p> <p>Spray performance can be affected by a variety of factors.</p>	<p>With or without streaking</p> 	<p>Spray impact</p> 	<p>Spray droplet diameter</p> 	<p>Wear resistance</p> 	<p>Chemical resistance</p> 	<p>Heat resistance</p> 	<p>Pressure resistance</p> 	<p>Viscosity</p> 

Although there are many opinions on the classification of spray droplet sizes, IKEUCHI, "The Fog Engineers", classify them as shown below.

Coarse Fog

Rain-Storms
Over 1.0 mm

Spray Nozzle Materials

Listed below are the materials of nozzles and parts, as well as resistance characteristics of each material against common chemicals. For more information on resistance characteristics, please see the technical references at the end of this catalog.

The standard and optional materials available for the nozzles are shown in the material table of each nozzle series page, using the material codes shown on this page. If you need a specific nozzle material that is not mentioned in the material table, please contact us.

Material List

Metals	[Material code Material]
	S303 Stainless steel 303
	S304 Stainless steel 304
	S316 Stainless steel 316
	S316L Stainless steel 316L
	SCS13 Die-cast stainless steel equiv. to S304
	SCS14 Die-cast stainless steel equiv. to S316
	SCS16 Die-cast stainless steel equiv. to S316L
	S420J2 Hardened stainless steel 420J2
	B Brass C3604

Rubbers	[Material code Material]
	NBR Nitrile rubber
	FKM Fluororubber
	FEPM Tetrafluoroethylene-propylene rubber
	EPDM Ethylene-propylene rubber

Ceramics	CERJET® Ceramics
	Alumina ceramics (Alumina 92%, etc.)
	[Material code Material]
	SiC Silicon nitride bonded silicon carbide
SiSiC Sintered reaction-bonded silicon carbide	

Plastics	[Material code Material]
	PP Polypropylene
	PPS Polyphenylene sulfide
	PVC Polyvinyl chloride
	HTPVC Heat-treated polyvinyl chloride
	PTFE Polytetrafluoroethylene
	PCTFE Polychlorotrifluoroethylene
	PVDF Polyvinylidene fluoride
	FRPP Glass-fiber reinforced polypropylene
	PA Polyamide
	PE Polyethylene
	Ultra-high molecular weight polyethylene (UHMWPE)
	Polyester elastomer
Araldite®*1 Epoxy resin (Adhesive)	
Araldite®H High-temperature epoxy resin (Adhesive)	

*1) Araldite is the registered trademark of Huntsman Advanced Materials.

Oil-free options are available at additional cost. Contact us for details.

Table of Chemical and Heat Resistance

Materials	Items	Chemical resistance												Heat resistance*2	
		Hydrochloric acid	Concentrated Hydrochloric acid	Sulfuric acid (35%)	Concentrated sulfuric acid	Nitric acid (35%)	Concentrated nitric acid	Acetic acid	Sodium hydroxide (caustic soda)	Aqueous ammonia	Acetone	Trichloroethylene	Ethyl alcohol	Suitable (°C)	Short-term use only (°C)
Metals	S303	x	x	x	x	o	Δ	Δ	o	o	o	o	o	400	800
	S304	x	x	x	x	o	o	o	o	o	o	o	o	400	800
	S316, S316L	x	x	x	o	o	Δ	o	o	o	o	o	o	400	800
	B	x	x	x	x	x	x	x	Δ	Δ	o	o	o	200	400
Plastics	PP	o	Δ	o	x	x	x	o	o	o	o	Δ	o	80	90
	PPS	o	o	o	Δ	Δ	x	o	o	o	o	o	o	170	180
	PVC	o	o	o	o	o	x	o	o	o	x	x	o	40	50
	HTPVC	o	o	o	o	o	x	o	o	o	x	x	o	50	70
	PTFE	o	o	o	o	o	o	o	o	o	o	o	o	100	150
	PVDF	o	o	o	o	o	o	o	Δ	o	x	o	o	80	120
	FRPP	o	Δ	o	x	x	x	o	Δ	o	o	Δ	o	90	100
	PA	x	x	x	x	Δ	Δ	Δ	o	o	o	o	Δ	130	230
	UHMWPE	o	o	o	x	Δ	x	o	o	o	Δ	Δ	o	80	100
	Polyester elastomer	x	x	x	x	x	x	o	Δ	x	Δ	Δ	o	100	120
Rubbers	Araldite®	Δ	x	Δ	x	x	x	x	x	x	x	x	x	60	70
	Araldite®H	o	x	o	Δ	x	x	o	Δ	o	o	o	o	120	140
	NBR	x	x	x	x	x	x	o	o	o	x	Δ	o	90	120
	FKM	o	o	o	o	o	o	o	Δ	x	x	o	o	150	200
	FEPM	o	o	o	o	o	o	o	o	x	x	o	o	150	200
Ceramics*3	EPDM	o	Δ	o	Δ	x	x	o	o	o	o	x	o	90	120
	CERJET® ceramics	o	o	o	o	o	o	o	x	o	o	o	o	700	800
	Alumina ceramics	o	o	o	o	o	o	o	Δ	o	o	o	o	1,000	1,200
	SiC	o	o	o	o	o	o	o	Δ	o	o	o	o	1,550	1,550
SiSiC	o	o	o	o	o	o	o	Δ	o	o	o	o	1,350	1,350	

*2) The heat resistance (operating temperature limit) of spray nozzles varies widely depending on the operating conditions, environment, liquid sprayed, etc.

*3) Ceramic should be used at temperatures under 100°C to avoid a crack caused by heat shock.

Note: As for the spray nozzles including adhesive, please also take into account the heat/chemical resistance of the adhesive.

o... Suitable
 Δ... Possible for short term
 x... Unusable

Technical Data for Nozzles

Spray Performance to Consider

Changes in Spray Pattern According to Water Pressure

The spray pattern describes the cross sectional shape of the spray. By selecting the spray pattern most suitable for the particular application the most efficient spray performance will be achieved.

The spray pattern changes with the gradual increase in spray pressure.

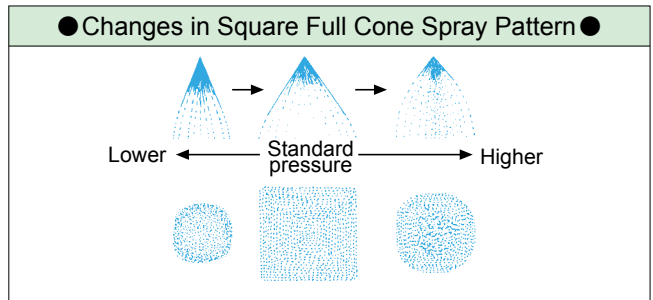
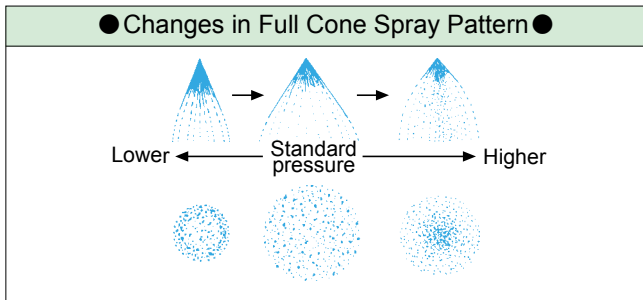
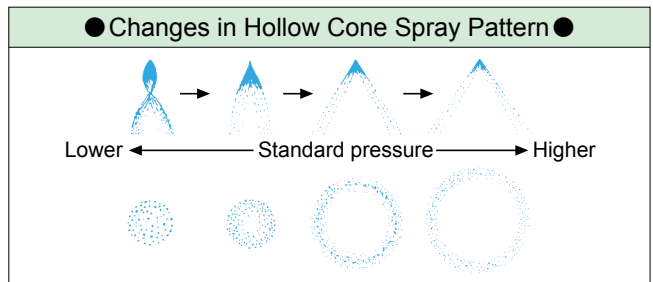
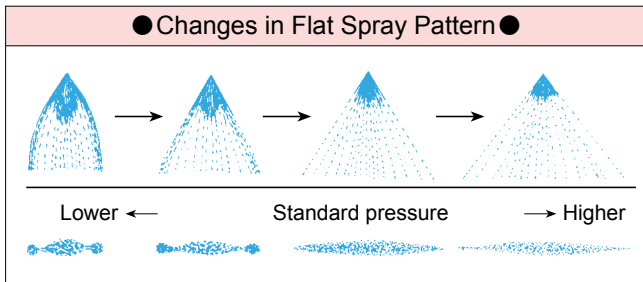
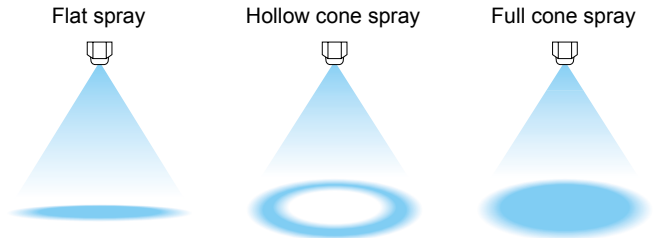

Spray Angle and Width

The spray angle is the angle of spray measured near the nozzle orifice.

The table below shows the calculated spray width, based on the spray angle.

The spray width varies depending on the spray height. As the spray goes farther from the nozzle, the droplets gradually lose momentum and the covered area will not continue to increase at a certain distance from the nozzle orifice.

Be aware that the actual spray width is smaller than the calculated values. This needs to be considered when designing a nozzle layout.

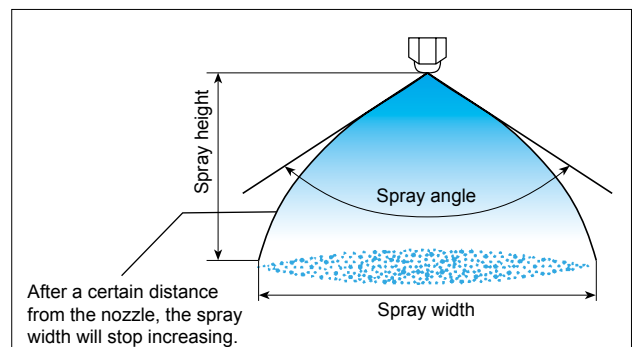

		Calculated values of spray width (mm)												
Spray angle		150°	140°	130°	115°	100°	90°	80°	65°	50°	40°	25°	15°	12°
Spray height (mm)	10	74.6	54.9	42.9	31.4	23.8	20	16.8	12.7	9.3	7.3	4.4	2.6	2.1
	20	149	110	85.8	62.8	47.7	40	33.6	25.5	18.7	14.6	8.9	5.3	4.2
	50	373	275	214	157	119	100	83.9	63.7	46.6	36.4	22.2	13.2	10.5
	70	522	385	300	220	167	140	117	89.2	65.3	51.0	31.0	18.4	14.7
	100	746	549	429	314	238	200	168	127	93.3	72.8	44.3	26.3	21.0
	150	1,120	824	643	471	358	300	252	191	140	109	66.5	39.5	31.5
	200	1,492	1,099	858	628	477	400	336	255	187	146	88.7	52.7	42.0
	250	1,866	1,374	1,072	785	596	500	420	319	233	182	111	65.8	52.6

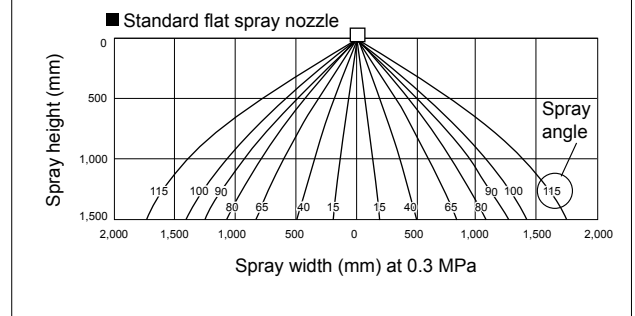

Technical Data for Nozzles

■ Calculating Spray Capacity

Spray Capacity vs. Liquid Density

The spray capacities listed in this catalog are based on tap water at room temperature. The spray capacity changes depending on the liquid density.

In general, the spray capacity increases when either the liquid density decreases or the spray pressure increases.

The spray capacity is inversely proportional to the square root of the liquid density. To determine the spray capacity of a liquid having density (γ), multiply the spray capacity value shown in our catalog by $\frac{1}{\sqrt{\gamma}}$.

Spray Capacity vs. Liquid Pressure

The spray capacity increases and decreases proportionally to the square root of the liquid pressure. If the spray capacity (Q_x) at a certain pressure (P_x) is not listed in the catalog, an approximate value can be calculated by using the following equation:

$$Q_x = Q \sqrt{\frac{P_x}{P}}$$

P: Known pressure
 Q: Spray capacity at the pressure of P (see the catalog table)
 P_x: Pressure to be applied
 Q_x: Expected spray capacity (approximate value)

Example:
 Calculate spray capacity for the capacity code 20 at a pressure of 0.4 MPa.

Spray capacity code	Spray angle (°)		Spray capacity (L/min)		
	0.3 MPa	0.7 MPa	0.2 MPa	0.3 MPa	0.5 MPa
20	80	86	1.63	2.00	2.58
40	80	83	3.27	4.00	5.16
60	80	83	4.90	6.00	7.75

Enter 0.3 MPa* as P and 2.00 L/min as Q. (*Select the value nearest to P_x from the catalog table as P)

$$Q_x = 2.00 \times \sqrt{\frac{0.4}{0.3}} \approx 2.31 \text{ L/min}$$

■ Changes in Spray Distribution

Spray distribution is defined as the distribution of the spray flow in the direction of spray width. The spray distribution varies depending on the spray height and pressure.



Ring-shaped distribution



Even distribution

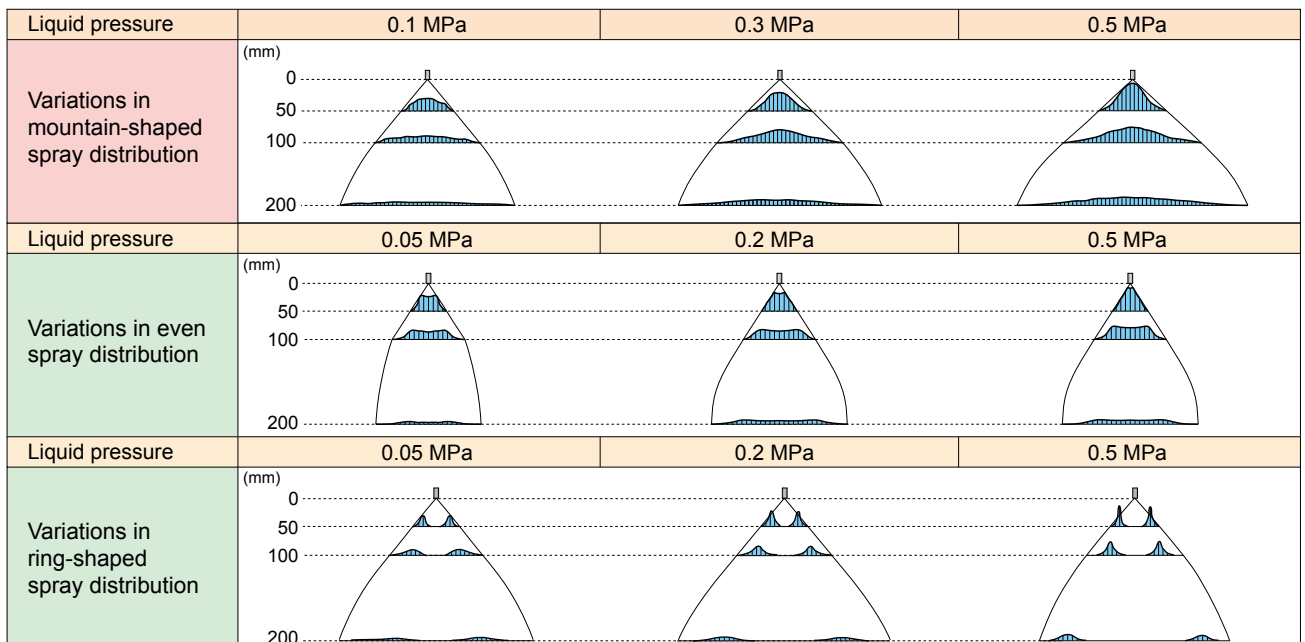

Technical Data for Nozzles

■ Spray Distribution in a Multi-Nozzle Arrangement

The characteristics of the spray distribution differ depending on the type of flat spray nozzle.

A mountain-shaped spray distribution is strong in the center and gradually tapers and weakens towards the edges. It is useful in producing a uniform spray distribution across the entire spray width in a multi-nozzle arrangement by overlaying patterns, but the spray impact is not distributed evenly.

On the other hand, an even spray distribution, produced by an even flat spray nozzle, provides a spray flow rate and impact that is distributed evenly across the entire spray width. This distribution is suitable for cleaning when the cleaning power should be distributed evenly across the entire spray width with a single nozzle.

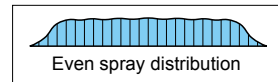
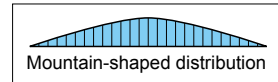

Standard Flat Spray Nozzle (Mountain-Shaped Distribution)

IKEUCHI's standard flat spray nozzles are designed to produce a mountain-shaped distribution in order to obtain a uniform spray distribution in a multi-nozzle arrangement. Spray distribution depends on the spray height, nozzle spacing, liquid pressure and nature, as well as the quality of the nozzles. It is not possible to achieve a uniform spray distribution if the individual nozzles have variations in product quality (see Fig. A).

IKEUCHI guarantees their spray nozzle for spray angle and spray capacity, which makes uniform distribution possible as designed (see Fig. B).

(A) Spray distribution of nozzles with no quality guarantee

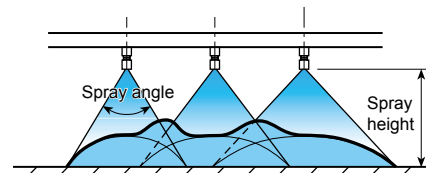

Uniform distribution is not obtained.

(B) Spray distribution of IKEUCHI nozzles with quality guarantee

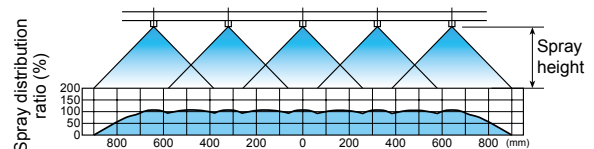

When using nozzles with a spray performance guarantee, uniform distribution can be obtained by overlapping mountain-shaped distribution.

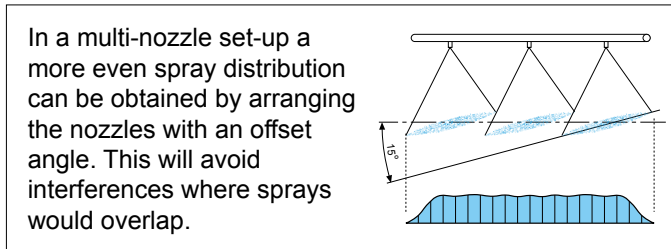

Even Flat Spray Nozzle

These nozzles are designed to produce an even spray distribution with an even cleaning power across the width of the spray.

Please note that using even flat spray nozzles in multi-nozzle arrangements will not create a uniform spray distribution (see Fig. C).

(C) Multi-nozzle arrangement using even flat spray nozzles

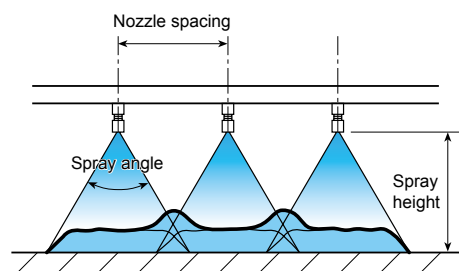

Spray distribution loses uniformity in overlapped spray areas.

Technical Data for Nozzles

Methods to Measure Spray Droplet Diameter

We use the immersion sampling method and the laser analyzer method to measure spray droplet size. The values shown for spray droplet diameters in this catalog are measured with the immersion sampling method.

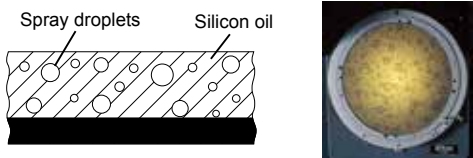
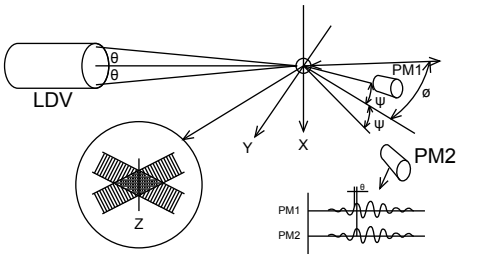
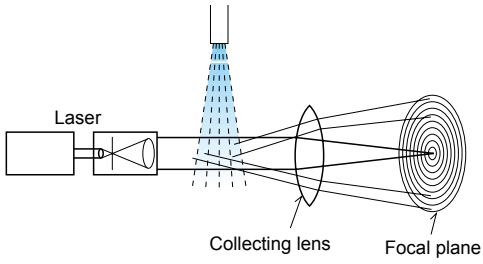
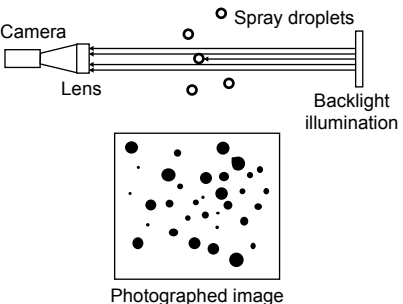
Measuring method	Range of measured droplet size
Principle and features	
Immersion Sampling Method	
<p>Droplets are collected on a glass plate coated with silicon oil and a magnified photo is taken immediately for subsequent scanning. The collected droplets remain suspended as perfect circles. This method is less affected by distance and droplet concentration. However, ultra-fine droplets are unable to break the surface tension of the oil and evaporate. This results in an average droplet size larger than the actual value.</p>	 <p style="text-align: right;">10–5,000 μm</p>
Laser Analyzer	
1. Laser Doppler Method	
<p>This method forms interference fringes by crossing two laser beams. Then, the spray droplet size is calculated from the phase difference at the time of detecting scattered light, which has resulted from droplets having passed through these interference fringes, by multiple photo detectors provided at a given distance. This method is less affected by droplet concentration because each droplet is measured one by one, while enabling simultaneous measurement of droplet velocity. However, measurement is only possible at a single point in the spray.</p>	 <p style="text-align: center;">(LDV: Laser Doppler Velocimeter PM: Phase monitor)</p> <p style="text-align: right;">0.5–2,500 μm</p>
2. Fraunhofer Diffraction Method	
<p>A laser beam scatters at the surface of droplets to form a diffracted image behind the droplets due to the interference of the scattered light (Fraunhofer diffraction). This method can simultaneously measure all droplets on the laser beam path, but if the droplet concentration is too high, the laser beam once scattered may be scattered again by other droplets (multiple scattering). This phenomenon may cause the measured droplet size to be smaller than the actual droplet size.</p>	 <p style="text-align: right;">1–1,000 μm</p>
Shadowgraph Method	
<p>Backlight illuminated shadows of droplets in various sizes are photographed and converted to circular shapes, from which the droplet diameters are calculated. This method enables the measurement of non-spherical coarse droplets that cannot be measured by the laser analyzer. However, it is not suitable for measuring fine droplets due to the low magnification of the camera. Also, when the droplets are dense, the overlapped multiple droplets could be measured as a single droplet, thus its droplet size may appear larger than the actual size.</p>	 <p style="text-align: right;">10–8,000 μm</p>

Technical Data for Nozzles

Mean Droplet Diameter

The mean droplet diameter is an important factor in selecting nozzles and designing nozzle-related equipment. It varies depending on the type of spray nozzle, liquid pressure, and spray capacity.

If the spray conditions, such as spray pressure, capacity and angle, are kept the same, the mean droplet diameter of a hollow cone spray nozzle is the smallest among hydraulic nozzles.

The smaller the mean droplet diameter, the larger the surface area that contacts air, increasing the contact efficiency and effect on chemical reactions, absorption, adsorption, etc.

Hollow cone spray nozzles are suitable for cooling and purifying gases, humidifying, and chemical reactions.

Generally, the following average value models are used for mean droplet sizes:

- Sauter Mean Diameter (\bar{d}_{32}) $\frac{\sum nd^3}{\sum nd^2}$
- Volume Mean Diameter (\bar{d}_v) $(\frac{\sum nd^3}{\sum n})^{1/3}$
- Mass Median Diameter ($D_{v,5}$) $f_0^{D_{v,5}} dv/v =$
 $f_{D_{v,5}}^\infty dv/v = 50\%$

In chemical processes such as cooling, evaporation, combustion and drying, the surface-to-volume ratio, i.e. specific surface area, is used to determine the efficiency.

Because the rate of reaction is influenced more by a small number of large droplets than a large number of small droplets, it is advisable to use the Sauter Mean Diameter as a representative value for the droplet size.

The Sauter Mean Diameter is used most often and is the one used in this catalog.

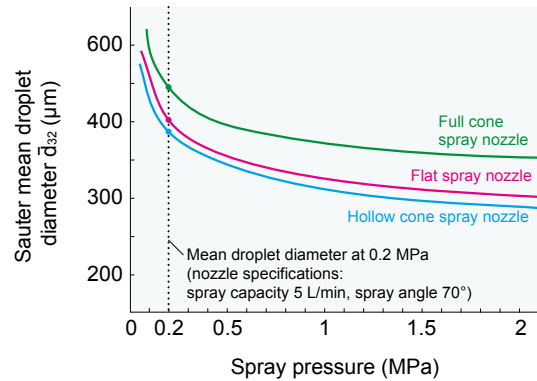

Example of calculation of Sauter mean diameter

Range (μm)	Median d (μm)	Quantity n	nd ²	nd ³
0–100	50	1,664	4,160,000	208,000,000
100–200	150	2,072	46,620,000	6,993,000,000
200–300	250	444	27,750,000	6,937,500,000
300–400	350	161	19,722,500	6,902,875,000
400–500	450	73	14,782,500	6,652,125,000
500–600	550	35	10,587,500	5,823,125,000
600–700	650	17	7,182,500	4,668,625,000
700–800	750	4	2,250,000	1,687,500,000
	Total	4,470	133,055,000	3.987275×10 ¹⁰

$$\bar{d}_{32} = \frac{\sum nd^3}{\sum nd^2} = 299.6711886 = 300 \mu\text{m}$$

Correlation of Spray Droplet Diameter

Results will differ, depending on the method used to measure. If the Sauter mean droplet diameter measured with the immersion sampling method equals 1, as relative coefficient number, this value will be different when measured with other methods, as shown on the right.

Measuring method Nozzle type	Immersion sampling method	Fraunhofer diffraction method	Laser Doppler method	Shadowgraph method
Hydraulic spray nozzles	1	0.45	0.7–0.9	0.8–0.9
Pneumatic spray nozzles				

Technical Data for Nozzles

Spray Nozzle Characteristics

Free Passage Diameter and Clog Prevention

The free passage diameter gives the approximate minimum dimension for a liquid to freely pass through a nozzle.

Flat Spray Nozzle

The flat spray nozzle orifice is cat-eye shaped and the free passage diameter is the orifice width multiplied by a safety factor.

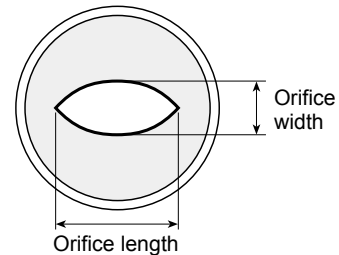

Cone Spray Nozzle

The typical full cone spray nozzle includes a whirler which forms a round spray area with uniform distribution. The smallest dimension of liquid passage in the nozzle depends on the whirler.

The diameter of a sphere that can pass through the whirler is defined as free passage diameter.

For hollow cone spray nozzles without whirler and solid stream spray nozzles, the free passage diameter is either the diameter of the nozzle inlet or of the orifice, whichever is smaller.

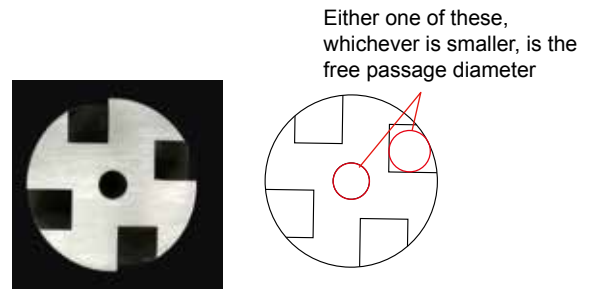

Clog Prevention

The whirler is the bottleneck in the liquid passage and where clogging can occur. There are several types of whirlers such as X-shaped, disc-shaped, and spiral shaped.

The X-shaped whirler has the largest free passage diameter and therefore has the least risk of clogging.

The hollow cone spray nozzles AAP (p. 61), the TAA series (p. 63), and the full cone spray nozzles AJP series (p. 84) have no whirler or other obstructions in the nozzle interiors and are therefore the most clog-resistant.



Technical Data for Nozzles

■ Spray Impact

Spray impact describes the force with which the spray droplets hit the target surface. The stronger the spray impact, the better the cleaning effect.

Solid stream jet nozzles have the strongest spray impact (see Fig. 1). The wider the spray angle and the larger the spray area becomes, the weaker the spray impact. The spray impact also decreases as the distance between the nozzle and the object increases (see Fig. 2).

Given the same pressure, the larger the spray capacity the nozzle has, the stronger the spray impact and cleaning effect (see Fig. 3).

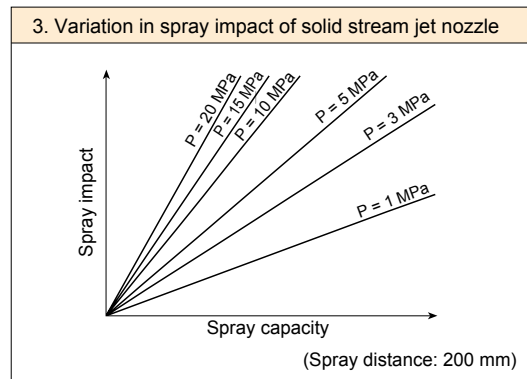
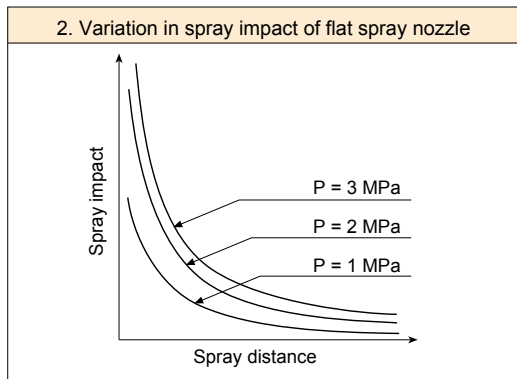
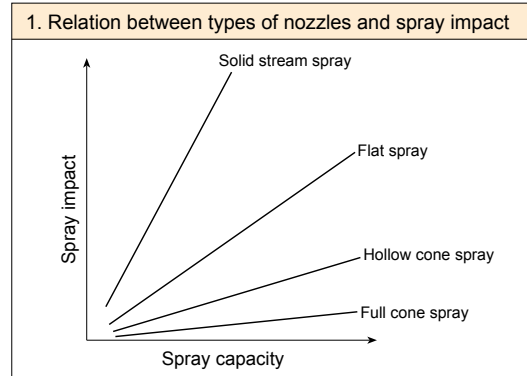

P = Spray pressure

■ Viscosity

In general, as the liquid viscosity increases, the spray capacity and angle decrease, the spray distribution loses uniformity and the droplet size increases. High liquid viscosity increases the resistance inside the pipe supplying the nozzle, causing a drop in the liquid pressure which also needs to be considered.

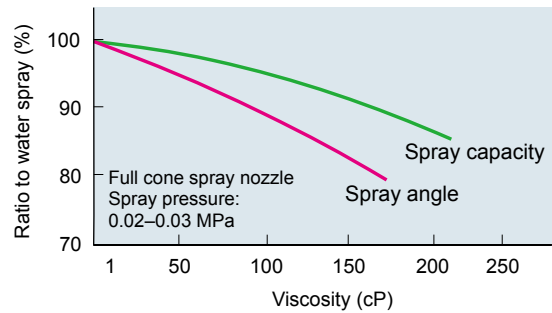

Increased viscosity in hollow cone spray nozzles decreases the movement of the whirler, deteriorating the spray distribution. The spray capacity of a hollow cone spray nozzle increases but the spray angle decreases as the viscosity of the liquid increases.

Please contact us for details as the results may differ depending on the nozzle type.

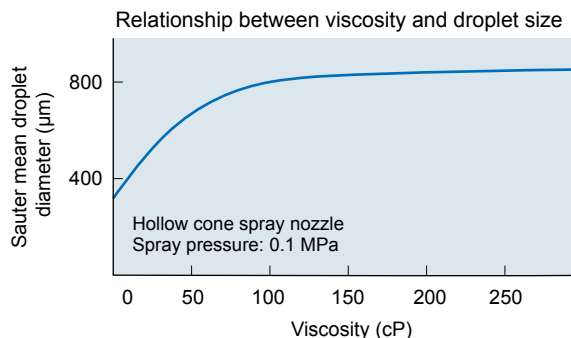
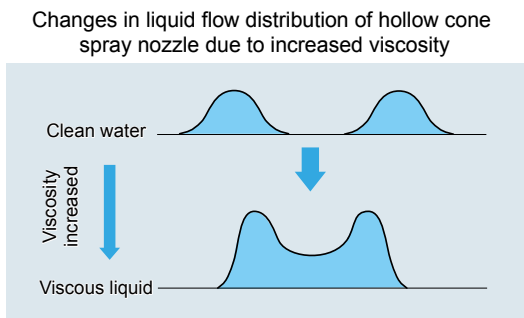

Technical Data for Nozzles

■ Heat Resistance

The temperature a spray nozzle can withstand varies greatly depending on the environmental conditions and the properties of the spray liquid. Please refer to page 7 for the heat resistance of materials. For nozzles including adhesives it is important to also consider the heat resistance of the adhesive.

The ceramic tips of CERJET will crack if abruptly cooled down from high temperatures (200°C). Alumina ceramics will crack due to temperature changes of 100°C or more.

Nozzles made of special materials are available on request.

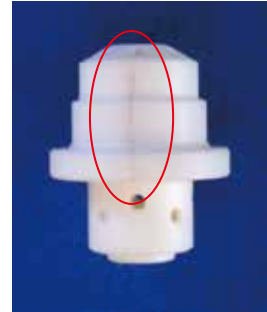

Nozzle cracked due to abrupt cooling

■ Pressure Resistance

Each nozzle series is carefully designed to withstand specific pressures. Depending on the operating system, sudden pressure can be three to five times as much as the spray pressure. Consider measures to prevent these sudden pressure increases or surges in water pressure. For high pressure use, metal nozzles are recommended over plastic nozzles.

■ Tightening torque

Cautions for the CERJET nozzles with ceramic orifice:
Avoid screwing CERJET nozzles in too tight. Possible nozzle body distortions can cause cracks in the ceramic orifice.
Tighten only to the recommended torque, not exceeding the following values:

8 N-m for size R1/8
15 N-m for size R1/4
(For stainless steel or brass body)

■ Chemical Resistance

When spraying chemicals or using spray nozzles in a corrosive environment, chemical-resistant materials should be used to avoid deterioration of nozzles.

Please refer to page 7 for the chemical resistance of materials.
For nozzles including adhesives, also consider the chemical resistance of the adhesive.

Besides the optional materials, nozzles are available in special materials upon request.

■ Advantages of Ceramic Nozzle

CERJET is a metal nozzle with a ceramic orifice. The standard material used for the body is stainless steel 303. The ceramic orifice is highly resistant to wear and chemicals, not damaged by most acids and other highly corrosive chemicals, except hydrofluoric acid and alkali liquids of pH12 and above.

However, the epoxy resin adhesive Araldite® is used for bonding the ceramic orifices into the metal body. For those applications possibly corroding adhesives or metal nozzle bodies, it is recommended to use a CERTIIM nozzle, an engineered plastic body molded around a ceramic orifice. CERTIIM includes VP-TPVDF (page 10) and VEP-TPVDF (page 20).

Technical Data for Nozzles

Wear Resistance

Nozzle Wear

Nozzle tips and orifices are constantly subjected to the flow of high speed liquid exposing them to wear. If the liquid is circulated and re-used, slurry and other dirt particles will enter, wearing tips and orifices out even faster.

Increased wear will narrow the spray angle of a flat spray nozzle and worsen its spray distribution. In high-pressure cleaning, worn nozzles cause the pump pressure to drop and the cleaning effect will rapidly degraded.

In hollow cone spray nozzles an air core is generated in the center of a vortex. This can cause wear at the tip of the air core, especially if the spraying liquid contains slurry or the like. To maintain optimum nozzle performance selecting a wear-resistant material is recommended.



Orifice worn out by slurry

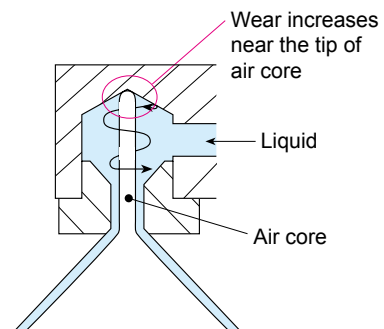

Difference in Wear Resistance by Material

The figure shows the increase in flow for each nozzle due to worn orifices.

The shaded area indicates the excess spray flow from a stainless steel nozzle relative to a CERJET during the same spray time (t).

The ceramic orifice of CERJET spray nozzle has an outstanding wear resistance, with a hardness of 7 on the Mohs scale. It can last 20–30 times longer than stainless steel nozzles and several hundred times longer than brass ones.

CERJET is recommended for applications requiring wear-resistant nozzles, including high-pressure cleaning and for use with liquids containing slurry.

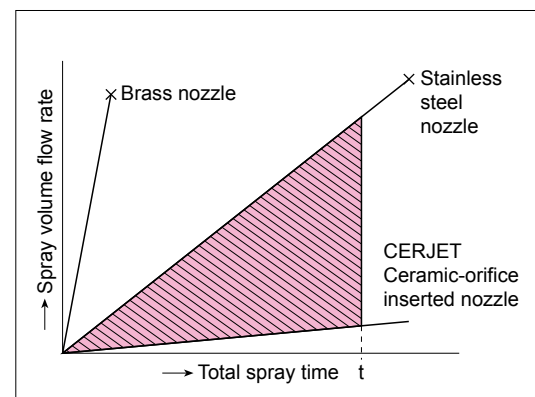

Technical Data for Nozzles

Strainer

Not all nozzles are equipped with strainers, some nozzles have the option of adding a strainer. Strainer usually includes a strainer holder, a strainer screen, and a strainer cap. When ordering a strainer be sure to select an appropriate mesh size according to the free passage diameter of the nozzle.

Strainer screen		Free passage diameter of nozzle (mm)
Mesh size	Opening (mm)	
#200	0.07	Less than 0.3
#150	0.10	0.3 to under 0.5
#100	0.15	0.5 to under 0.8
#50	0.30	0.8 to under 1.0

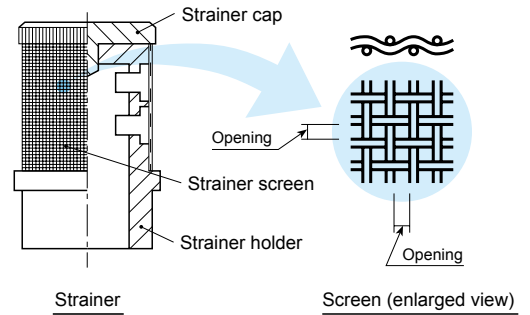

Nozzle Reaction Force

When spraying high-pressure water, a reaction force acts in the direction opposite to the direction of spray. To calculate the approximate reaction force (F) use the following equation.

$$F = 0.745 \cdot Q \cdot \sqrt{P}$$

F: Reaction force (N)
Q: Spray capacity (L/min)
P: Spray pressure (MPa)

Rotation Reaction Force

In a full cone spray nozzle with whirler, a rotation torque (T) is generated as a reaction force to the vortex current produced by the whirler.

Rotation torque acts in the same direction as tightening the nozzle.

The rotation torque (T) can be calculated with the following equation.

$$T \approx C \cdot Q \cdot D \cdot \sqrt{P}$$

T: Torque (N-m)
C: Constant
Q: Spray capacity (L/min)
D: External diameter of whirler (mm)
P: Spray pressure (MPa)

Diagonal Dimension Calculation

To calculate the approximate diagonal dimension of a hexagon, multiply the width across flats by 1.16.

Example:

In the figure on the right, the dimension H is 12 mm, so the diagonal dimension would be 13.92 (12 × 1.16 = 13.92).

Example: Drawing of VVP series

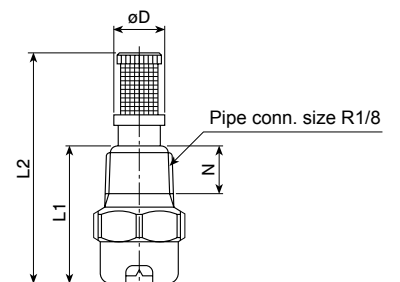

Dimensions of of VVP series

Dimensions (mm)				
L1	L2	H	øD	N
18.5	31	12	7.5	6.5

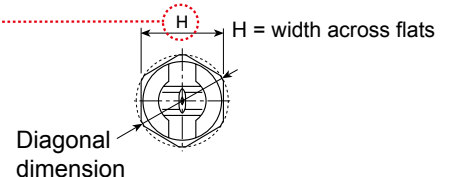

How to Use the CAD Data Website

Some products have 3D/2D CAD data available for download from the website. Feel free to explore this service. The following is a brief introduction on the use of the CAD data website. Free account registration is necessary to download data and update previews.

1. Jump to the Website and Search the Series

Via Smartphone

Scan the 2D code on the right.



Via PC

Access it through the download page of IKEUCHI's website.
<https://www.dry-fog.com/en/documents/cad/>

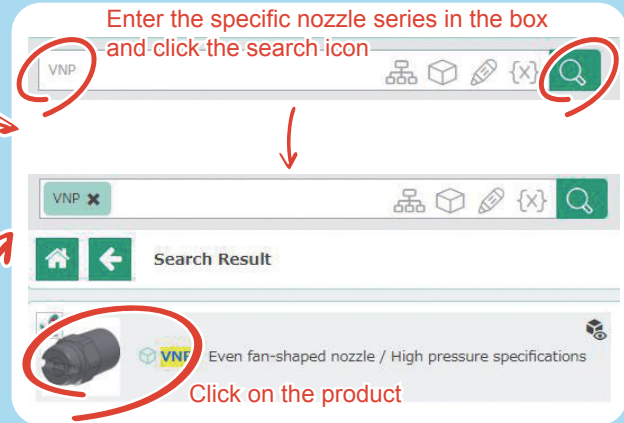
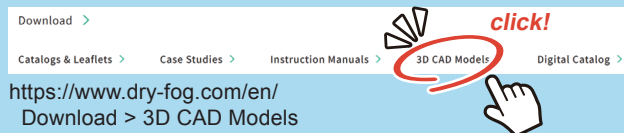

2. Choose Product Specifications

The product page will be displayed.

Select specifications such as thread size, spray angle/capacity code, material, then update the preview.

If a list of items is shown instead of a drop-down, check the circle next to the corresponding product name to select it.

Selectable products: 1

Company	IKEUCHI	
Description	VNP - Even fan-shaped nozzle / High pressure specifications	
Bill of material	1/8MVNP2599BR-S303	
CNSORDERNO	1/8MVNP2599BR-S303	
Order number		
SERIES	VNP	
Series		
PCS	1/8	
Pipe con. size		
CJA	25	
Classification of jet angle		
SCC	99	
Spray capacity code		
MM	S303	
Main material		
L1	16.5	mm
Dimension		
H	12	mm
Dimension		
N	7.0	mm
Dimension		
MA	7	g
Mass		

The yellow boxes offer different options in the drop-down menus

After selecting the specifications, click here to update the preview

3. Generate and Download CAD data

Select the file format for the CAD data in the **Generate CAD** section. After setting the format, download the data.



Reference Data

Conversion of Units

Length	μm	mm	cm	m	in	ft
	1	1×10^3	1×10^{-4}	1×10^{-6}	3.94×10^{-5}	3.28×10^{-6}
	1×10^3	1	0.1	1×10^{-3}	3.94×10^{-2}	3.28×10^{-3}
	1×10^4	10	1	1×10^{-2}	3.94×10^{-1}	3.28×10^{-2}
	1×10^6	1×10^3	100	1	3.94×10	3.28
	2.54×10^4	25.4	2.54	2.54×10^{-2}	1	8.33×10^{-2}
	3.05×10^5	3.05×10^2	3.05×10	3.05×10^{-1}	12	1

Area	cm^2	m^2	in^2	ft^2
	1	1×10^{-4}	0.155	1.08×10^{-3}
	1×10^4	1	1.55×10^3	10.8
	6.45	6.45×10^{-4}	1	6.94×10^{-3}
	9.30×10^2	9.30×10^{-2}	1.44×10^2	1

Volume	cm^3	L (Liter)	m^3 (kL)	ft^3	imperial gal.	U.S. gal.
	1	1×10^{-3}	1×10^{-6}	3.53×10^{-5}	2.2×10^{-4}	2.64×10^{-4}
	1×10^3	1	1×10^{-3}	3.53×10^{-2}	0.220	0.264
	1×10^6	1×10^3	1	35.3	220	264
	2.83×10^4	28.3	2.83×10^{-2}	1	6.23	7.48
	4.55×10^3	4.55	4.55×10^{-3}	0.16	1	1.2
	3.79×10^3	3.79	3.79×10^{-3}	0.134	0.833	1

Pressure	MPa	bar	kg/cm^2	psi (lb/in ²)	atm	mmHg	mmH ₂ O (mmAq)
	1	10	10.2	145	9.87	7.5×10^3	1.02×10^5
	0.1	1	1.02	14.5	0.987	750	1.02×10^4
	0.098	0.981	1	14.2	0.968	736	1×10^4
	6.89×10^{-3}	0.069	0.070	1	0.068	51.7	703
	0.101	1.01	1.03	14.7	1	760	1.03×10^4
	1.33×10^{-4}	1.33×10^{-3}	1.36×10^{-3}	0.019	1.32×10^{-3}	1	13.6
	9.81×10^{-6}	9.81×10^{-5}	1×10^{-4}	1.42×10^{-3}	9.68×10^{-5}	0.074	1

Flow rate	L/min	m^3/min	m^3/hr	in^3/hr	ft^3/hr	Imperial gal./min	U.S. gal./min
	1	1×10^{-3}	0.06	3.66×10^3	2.12	0.22	0.264
	1×10^3	1	60	3.66×10^6	2.12×10^3	220	264
	16.7	0.017	1	6.10×10^4	35.3	3.67	4.40
	2.73×10^{-4}	2.7×10^{-7}	1.64×10^{-5}	1	5.79×10^{-4}	6.01×10^{-5}	7.22×10^{-5}
	0.472	4.72×10^{-4}	0.028	1.73×10^3	1	0.104	0.125
	4.55	4.55×10^{-3}	0.273	1.66×10^4	9.63	1	1.20
	3.79	3.79×10^{-3}	0.227	1.39×10^4	8.02	0.833	1

Others

Viscosity	1 P = 100 cP 1 St = 100 cSt
Weight	1 kg \approx 2.21 lb 1 lb \approx 0.454 kg
Temperature	$[\text{°F}] \approx ([\text{°C}] \times 9/5) + 32$ $[\text{°C}] \approx 5/9 ([\text{°F}] - 32)$

Water flow rate and proper pipe size

Nominal size		Steel pipe		Flow rate (L/min) when pressure loss is 0.01–0.03 MPa per pipe length of 10 m
A	B	Inside dia. (mm)	Outside dia. (mm)	
6A	1/8B	6.5	10.5	1.3–2.2
8A	1/4B	9.2	13.8	3–5.2
10A	3/8B	12.7	17.3	7–12
15A	1/2B	16.1	21.7	12–21
20A	3/4B	21.6	27.2	22–38
25A	1B	27.6	34.0	38–65
32A	1 1/4B	35.7	42.7	70–120
40A	1 1/2B	41.6	48.6	120–210
50A	2B	52.9	60.5	215–370
65A	2 1/2B	67.9	76.3	410–700
80A	3B	80.7	89.1	680–1,200
100A	4B	105.3	114.3	1,200–2,100
125A	5B	130.8	139.8	2,100–3,600
150A	6B	155.2	165.2	3,300–5,700