

Standard Type Full Cone Spray Nozzles

Some Models are Made-to-Order

JJXP

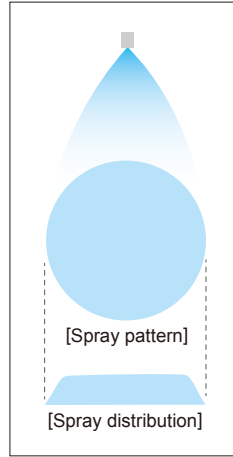

- Full cone spray pattern with a round impact area and uniform distribution.
- Spray capacity ranges from small to medium.
- X-shaped whirler provides a large free passage diameter, minimizing clogging.

[STANDARD PRESSURE]

0.2 MPa

[APPLICATIONS]

Cleaning: Gas, incinerator fumes, machinery, eliminators, screens, tanks, parts, crushed stone, earth and sand
 Cooling: Gas, machineries, tanks, steel
 Spraying: Waste water treatment, aeration, foam breaking, fire prevention and extinguishing, dust suppression, sea water desalination equipment

Full Cone

Structure	<ul style="list-style-type: none"> • One-piece structure with a press-fitted X-shaped whirler. • Size R1/4 with spray capacity codes 040-060 and size R3/8 standard models include a C-ring.
Material	<ul style="list-style-type: none"> • Sizes R1/8-Rc1: S303 • Sizes Rc1 1/2 or larger: S316 • Depending on nozzle code, S316L equivalent or SCS16 whirlers are also used. <p>SPECIAL ORDER MATERIAL*1: S316L, S316L, PP, or PTFE (PP and PTFE for Rc3/8 sizes and larger only)</p> <p>*1) Thread size of special order material may differ depending on the material.</p>

DWG No.	Pipe conn. size ²	Dimensions (mm)							Weight (g)
		L1	L2	L3	H	W	øD	N	
1	R1/8 (005)	20	32.5	-	12	-	-	7	9.5 ³
	R1/8 (010-030)	20	-	-	12	-	-	7	11
2	R1/4 (005)	20	32.5	-	14	-	-	10.5	18 ³
	R1/4 (010-030)	20	-	-	14	-	-	10.5	18
3	R1/4 (040-060)	28	-	-	14	-	-	10.5	21
4	R3/8	34	-	6	-	17	20	11	50
	Rc3/8	43	-	6	-	17	20	11	61
	Rc1/2	54	-	8	-	22	25	14	140
	Rc3/4	69	-	10	-	27	32	15	270
	Rc1	89	-	14	-	34	40	17	515
5	Rc1 1/2	124	-	20	-	50	58	19	1,520
	Rc2 (250-350)	160	-	24	-	60	70	23	2,600
	Rc2 (400-500)	118.5	-	24	-	60	70	23	2,050
	Rc2 1/2	147.5	-	27	-	80	90	27	4,360
	Rc3 (920)	163.5	-	30	-	90	105	30	6,700
Rc3 (1200)	170.5	-	30	-	90	105	30	6,500	

*2) Figures in () after the pipe connection size indicate the spray capacity code.
 *3) For JJXP005 with strainer, add 2g to the above weight.

DRAWING

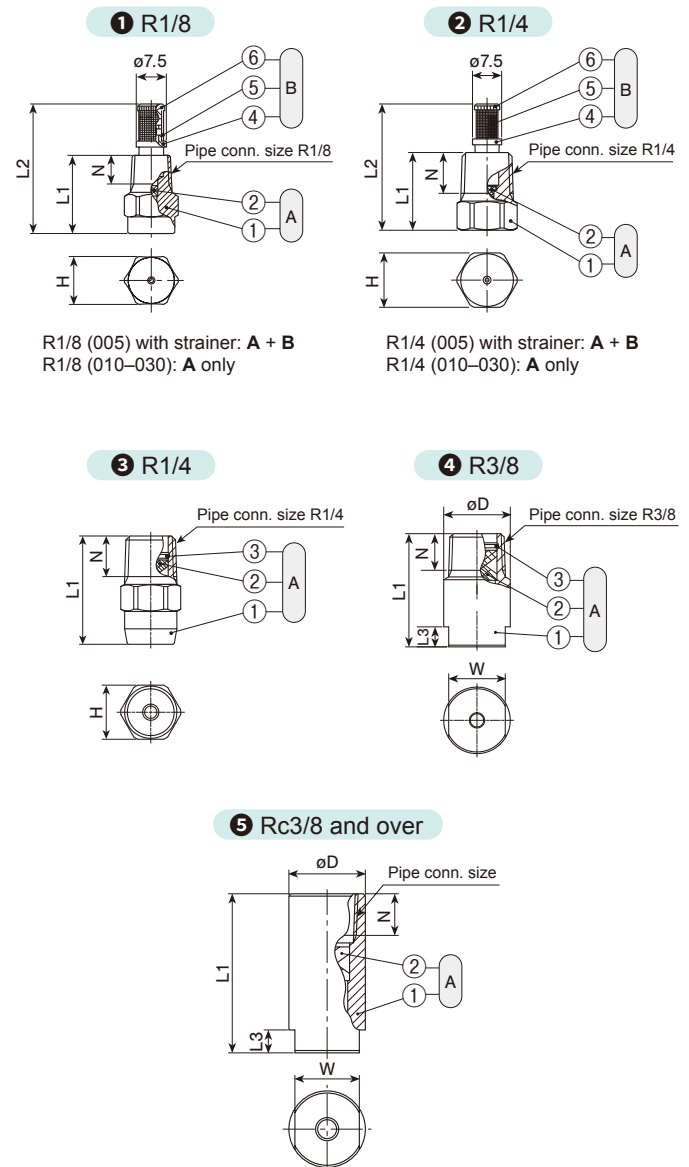

- (A) Nozzle (1) Nozzle body (2) Whirler (3) C-ring
 (B) Strainer (4) Strainer holder (5) Strainer screen [S316] (6) Strainer cap

[Note] Appearance and dimensions may differ slightly depending on material and nozzle code.

Full Cone

Spray capacity code	Pipe connection size				Spray angle (°)			Spray capacity (L/min)									Mean drop. dia. (µm)	Free pass. dia. (mm)
	R1/8	R1/4	R3/8	Rc3/8	0.05 MPa	0.2 MPa	0.5 MPa	0.03 MPa	0.05 MPa	0.1 MPa	0.15 MPa	0.2 MPa	0.3 MPa	0.5 MPa	0.7 MPa	1 MPa		
005	●	●			—	55	65	—	—	0.36	0.44	0.50	0.59	0.73	0.83	0.96	270	0.4
010	○	○			50	55	45	—	0.53	0.73	0.88	1.00	1.18	1.45	1.67	1.93	290	0.7
015	○	○			60	65	55	—	0.79	1.09	1.31	1.50	1.77	2.18	2.50	2.89	∩	0.8
020	○	○			60	65	55	—	1.06	1.46	1.75	2.00	2.36	2.91	3.34	3.86	∩	1.4
030	○	○			65	70	60	—	1.59	2.18	2.63	3.00	3.54	4.36	5.00	5.79	410	1.4
040		○			60	65	55	—	2.12	2.91	3.51	4.00	4.72	5.81	6.67	7.72	380	1.7
050		○			65	70	60	—	2.65	3.64	4.38	5.00	5.90	7.27	8.34	9.64	∩	1.7
060		○			70	75	65	2.51	3.18	4.37	5.26	6.00	7.08	8.72	10.0	11.6	520	1.7
070			○	○	60	65	60	2.93	3.71	5.09	6.13	7.00	8.26	10.2	11.7	13.5	480	1.9
080			○	○	65	70	65	3.35	4.24	5.82	7.01	8.00	9.44	11.6	13.3	15.4	∩	1.9
10			○	○	75	80	75	4.19	5.29	7.28	8.76	10.0	11.8	14.5	16.7	19.3	∩	2.6
12			○	○	80	85	80	5.03	6.35	8.73	10.5	12.0	14.2	17.4	20.0	23.1	660	2.6

Spray capacity code	Pipe connection size ⁴							Spray angle (°)			Spray capacity (L/min)									Mean drop. dia. (µm)	Free pass. dia. (mm)
	Rc 1/2	Rc 3/4	Rc 1	Rc 1 1/2	Rc 2	Rc 2 1/2	Rc 3	0.05 MPa	0.2 MPa	0.5 MPa	0.03 MPa	0.05 MPa	0.1 MPa	0.15 MPa	0.2 MPa	0.3 MPa	0.5 MPa	0.7 MPa	1 MPa		
14	○							65	70	55	5.86	7.41	10.2	12.3	14.0	16.5	20.3	23.3	27.0	590	3.5
16	○							70	75	60	6.70	8.47	11.6	14.0	16.0	18.9	23.3	26.7	30.9	∩	3.5
18	○							75	80	65	7.54	9.53	13.1	15.8	18.0	21.2	26.2	30.0	34.7	∩	3.5
20	○							80	85	70	8.38	10.6	14.6	17.5	20.0	23.6	29.1	33.4	38.6	740	3.5
23		○						70	75	60	9.63	12.2	16.7	20.2	23.0	27.1	33.4	38.4	44.4	630	4.7
26		○						75	80	65	10.9	13.8	18.9	22.8	26.0	30.7	37.8	43.4	50.1	∩	4.7
30		○						80	85	70	12.6	15.9	21.8	26.3	30.0	35.4	43.6	50.0	57.9	∩	4.7
35		○						85	90	75	14.7	18.5	25.5	30.7	35.0	41.3	50.9	58.4	67.5	∩	4.7
40		○						90	95	80	16.8	21.2	29.1	35.1	40.0	47.2	58.1	66.7	77.2	∩	4.7
45		○						90	95	80	18.8	23.8	32.7	39.4	45.0	53.1	65.4	75.0	86.8	950	4.7
50			○					70	75	60	20.9	26.5	36.4	43.8	50.0	59.0	72.7	83.4	96.4	800	6.0
60			○					80	85	70	25.1	31.8	43.7	52.6	60.0	70.8	87.2	100	116	∩	6.0
80			○					90	95	80	33.5	42.4	58.2	70.1	80.0	94.4	116	133	154	∩	6.0
90			○					90	95	80	37.7	47.7	65.5	78.9	90.0	106	131	150	174	1,150	6.6
100				○				80	85	70	41.9	52.9	72.8	87.6	100	118	145	167	193	1,000	8.4
150				○				85	90	75	62.8	79.4	109	131	150	177	218	250	289	∩	10.3
200				○				90	95	80	83.8	106	146	175	200	236	291	334	386	1,350	10.3
250					○			85	90	75	105	132	182	219	250	295	363	417	482	1,200	12.7
300					○			90	95	80	126	159	218	263	300	354	436	500	579	∩	12.7
350					○			90	95	80	147	185	255	307	350	413	509	584	675	∩	12.7
400					○			75	80	65	168	212	291	351	400	472	581	667	772	∩	13.2
500					○			95	95	80	209	265	364	438	500	590	727	834	964	1,500	14.1
600						○		75	80	65	251	318	437	526	600	708	872	1,001	1,157	1,500	16.9
700						○		85	90	75	293	371	509	613	700	826	1,017	1,167	1,350	1,800	16.9
920							○	100	100	85	385	487	669	806	920	1,086	1,337	1,534	1,775	1,660	18.1
1200							○	105	105	90	503	635	873	1,052	1,200	1,416	1,744	2,001	2,315	1,950	20.0

●: Available with or without strainer (mesh size #100) ○: Only available without strainer

*4) The JJXP series with thread size Rc2 1/2 and Rc3 are made-to-order.

For spraying slurry, the nozzle material should be wear-resistant. For such applications, the JJXP-AL92 series nozzles made of high-purity alumina are available (see page 71).

HOW TO ORDER

To inquire about or order a specific nozzle please refer to this coding system.

Example: 1/8M JJXP 005 S303 W

1/8M	JJXP	005	S303	W
Pipe conn. size ⁵		Spray capacity code	Material ⁶	Strainer
■ 1/8M		■ 005	■ S303	■ W (with strainer: JJXP005 only)
∩		∩	■ S316	■ (Blank indicates "without strainer")
■ 3F		■ 1200		

*5) "M" indicates male thread ("R" of the ISO standard) and "F" indicates female thread ("Rc" of the ISO standard), e.g. 1/8M = R1/8.
*6) See "Material" information on page 64 for standard material (S303 or S316) for each size.

The JJXP series with thread size Rc2 1/2 and Rc3 are made-to-order.

Standard Type Full Cone Spray Nozzles

JJXP-PVDF

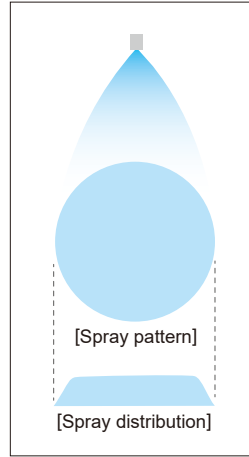

- Full cone spray pattern with a round impact area and uniform distribution.
- X-shaped whirler provides a large free passage diameter, minimizing clogging.

[STANDARD PRESSURE]
0.2 MPa

[APPLICATIONS]
 Cleaning: Machinery, screens, tanks, crushed stone, earth and sand
 Cooling: Machinery, tanks
 Spraying: Waste water treatment, aeration, foam breaking, dust suppression, etching, chemicals

Full Cone

Structure	• One-piece structure with a press-fitted X-shaped whirler.
Material	• PVDF

Pipe conn. size	Dimensions (mm)				Weight (g)
	L	H	øD	N	
R1/8	18	12	11	8	2.2
R1/4	22	14	12	11.5	3.8

[Note] Appearance and dimensions may differ slightly depending on material and nozzle code.

DRAWING

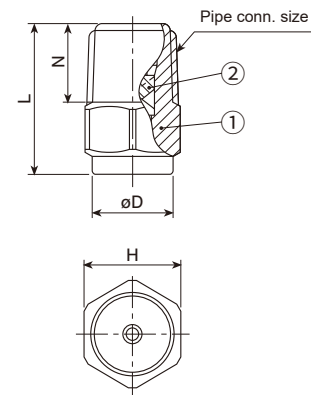

① Nozzle body ② Whirler

Spray capacity code	Pipe conn. size		Spray angle (°)			Spray capacity (L/min)									Mean droplet diameter (µm)	Free passage diameter (mm)
	R1/8	R1/4	0.05 MPa	0.2 MPa	0.5 MPa	0.03 MPa	0.05 MPa	0.1 MPa	0.15 MPa	0.2 MPa	0.3 MPa	0.5 MPa	0.7 MPa	1 MPa		
010	○	○	60	65	55	—	0.53	0.73	0.88	1.00	1.18	1.45	1.67	1.93	290	0.8
015	○	○	60	65	55	—	0.79	1.09	1.32	1.50	1.77	2.18	2.50	2.89	}	1.0
020	○	○	60	65	55	—	1.06	1.46	1.75	2.00	2.36	2.91	3.34	3.86		1.5
025	○	○	60	65	55	—	1.32	1.82	2.20	2.50	2.95	3.62	4.17	4.82		1.5
030	○	○	60	65	55	—	1.59	2.18	2.63	3.00	3.54	4.36	5.00	5.79	410	1.5

HOW TO ORDER

To inquire about or order a specific nozzle please refer to this coding system.

Example: 1/8M JJXP 010 PVDF

1/8M	JJXP	010	PVDF
Pipe conn. size*		Spray capacity code	Material
■ 1/8M		■ 010	
■ 1/4M		∩	
		■ 030	

*"M" indicates male thread ("R" of the ISO standard), e.g. 1/8M = R1/8.

Standard Type Full Cone Spray Nozzles

JJXP-HTPVC JJXP-PVC

For spraying chemicals such as hydrochloric acid, heat-treated HTPVC injection-molded [JJXP-HTPVC series] nozzles are available.

Full Cone

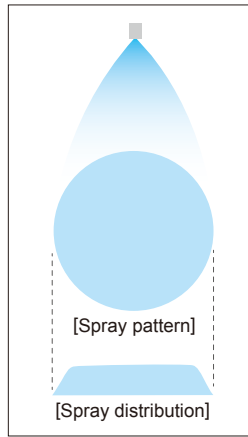

- Full cone spray pattern with a round impact area and uniform distribution.
- X-shaped whirler provides a large free passage diameter, minimizing clogging.

[STANDARD PRESSURE]
0.2 MPa

[APPLICATIONS]
Spraying: Etchants, chemicals
Cleaning: Printed circuit boards

JJXP-HTPVC SERIES

Structure	• One-piece structure with an X-shaped whirler.
Material	• HTPVC
Weight	• 2.5 g

[Note] Appearance and dimensions may differ slightly depending on material and nozzle code.

DRAWING

Unit: mm

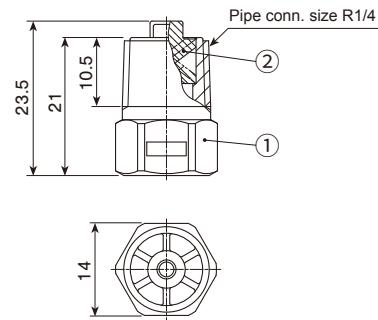

① Nozzle body ② Whirler

JJXP-PVC

Structure	• One-piece structure with an X-shaped whirler.
Material	• PVC
Weight	• 1.4 g

[Note] Appearance and dimensions may differ slightly depending on material and nozzle code.

DRAWING

Unit: mm

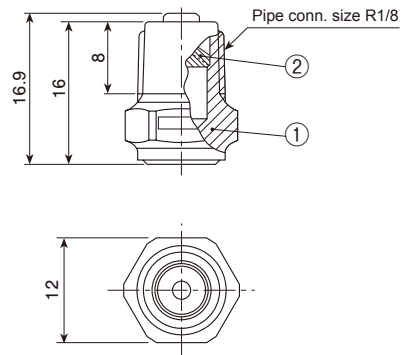

① Nozzle body ② Whirler

JJXP-HTPVC Series

Spray capacity code	Spray angle (°)			Spray capacity (L/min)									Mean droplet diameter (µm)	Free passage diameter (mm)
	0.05 MPa	0.2 MPa	0.5 MPa	0.03 MPa	0.05 MPa	0.1 MPa	0.15 MPa	0.2 MPa	0.3 MPa	0.5 MPa	0.7 MPa	1 MPa		
040	60	65	55	—	2.12	2.91	3.51	4.00	4.72	5.81	6.67	7.72	380	2.1
050	65	70	60	—	2.65	3.64	4.38	5.00	5.90	7.27	8.34	9.64	?	2.1
060	70	75	65	2.51	3.18	4.37	5.26	6.00	7.08	8.72	10.0	11.6	520	2.1

JJXP-PVC [1/8M JJXP 2*75/2 PVC]

Spray angle (°)			Spray capacity (L/min)									Mean droplet diameter (µm)	Free passage diameter (mm)
0.05 MPa	0.2 MPa	0.5 MPa	0.03 MPa	0.05 MPa	0.1 MPa	0.15 MPa	0.2 MPa	0.3 MPa	0.5 MPa	0.7 MPa	1 MPa		
70	75	66	—	1.06	1.46	1.75	2.00	2.36	2.91	3.34	3.86	350	1.5

HOW TO ORDER

To inquire about or order a specific nozzle please refer to this coding system.

JJXP-HTPVC

Example: 1/4M JJXP 040 HTPVC

1/4M JJXP **040** HTPVC

Pipe conn. size*

Spray capacity code

Material

- 040
- 050
- 060

JJXP-PVC

1/8M JJXP 2*75/2 PVC

Pipe conn. size*

Spray angle & capacity code

Material

*"M" indicates male thread ("R" of the ISO standard), e.g. 1/4M = R1/4.