

Instruction Manual for
BIM series with **SPB**-adaptor
BIM series with **SNB**-adaptor

Preface	P. 1
Safety Precautions	P. 1
1. Suggestions & Cautions	P. 2
2. Components of Nozzle	P. 5
3. Disassembly	P. 6
4. Cleaning	P. 7
5. Assembly	P. 7
6. Maintenance	P. 7
7. Troubleshooting	P. 8
8. Disposal	P. 9
9. Inquiries	P. 9



“The Fog Engineers”
H. IKEUCHI & CO., LTD.

Preface

Thank you for purchasing the Spray Nozzle from H. Ikeuchi & Co., Ltd.

This manual gives detailed instructions for the basic handling, maintenance and cautions of the product.

Please be aware that due to continuing efforts to improve our products, some details in this manual may differ from the actual product.

After reading, keep this manual handy for quick reference.

Safety Precautions

Prior to use, read this manual carefully and familiarize yourself with the proper operation of the product for optimal performance.

H. Ikeuchi & Co., Ltd. takes no responsibility for any accidents and/or injuries resulting from improper handling, installation and/or operation.



Wear safety gloves.

Screw threads, edges and corners may be sharp and could cause injury.



Ensure that the nozzle is firmly installed.

Loose screws may cause the nozzle to come off during operation and lead to serious accidents.

1. Suggestions & Cautions

- (1) Screw threads, edges and corners may be sharp. Wearing safety gloves is recommended.
- (2) Operate the nozzles under the specified pressures. If the pressure is not specified, refer to the provided flow-rate diagram.
- (3) Avoid damaging or scratching the nozzles and pipes. When replacing a nozzle tip or disassembling the nozzle for maintenance, always use a spanner, hexagon socket wrench, and milling vice. DO NOT use a pipe vice, pipe wrench, or pliers.
- (4) Spray ON/OFF control

Type SPB

This type has a built-in shutoff piston that operates on pilot air pressure. The spray is turned ON/OFF by turning the pilot air ON/OFF.

Use with pilot air pressure of 0.2 MPa or higher.

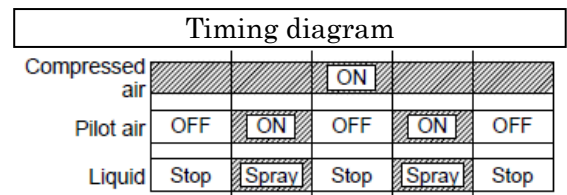

Type SNB

This type has a built-in shutoff piston that operates on compressed air (spray air) pressure. The spray is turned ON/OFF by turning the compressed air ON/OFF.

Use with compressed air pressure of 0.2 MPa or higher.

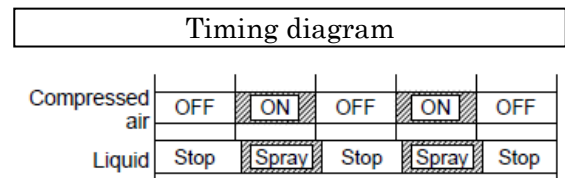

(a) Supply of Liquid

I) Liquid pressure type

Set the liquid pressure to 0.1 MPa or more.

If the liquid pressure is less than 0.1 MPa, irregular and intermittent spray may be caused.

II) Liquid siphon type

Set the siphon height to 500 mm or less.

If the siphon height is more than 500 mm, irregular and intermittent spray may be caused.

(b) Stop the liquid supply when not spraying for a long time.

(5) Air and liquid piping

- Use piping and valves large enough to prevent the pressure from dropping.
- Use new stainless steel pipes. Dust and foreign particles in old pipes may clog the nozzles. Never use pipes that may rust.
- Even new pipes may have chips, seal tape or other debris inside. ALWAYS flush pipes thoroughly before installing nozzles to remove any debris that could cause clogging.
- Install pressure gauges just before the nozzle to adjust air and liquid pressures appropriately. Installation of a valve is also recommended.
- Install strainers to prevent clogged nozzles. Clogging will impact nozzle performance.

Type SPB

Only stopping the pilot air will not purge air from the pipe and thus will not lower the pressure enough to stop the spraying. To prevent this, use a 3-way solenoid valve for the pilot air pipe.

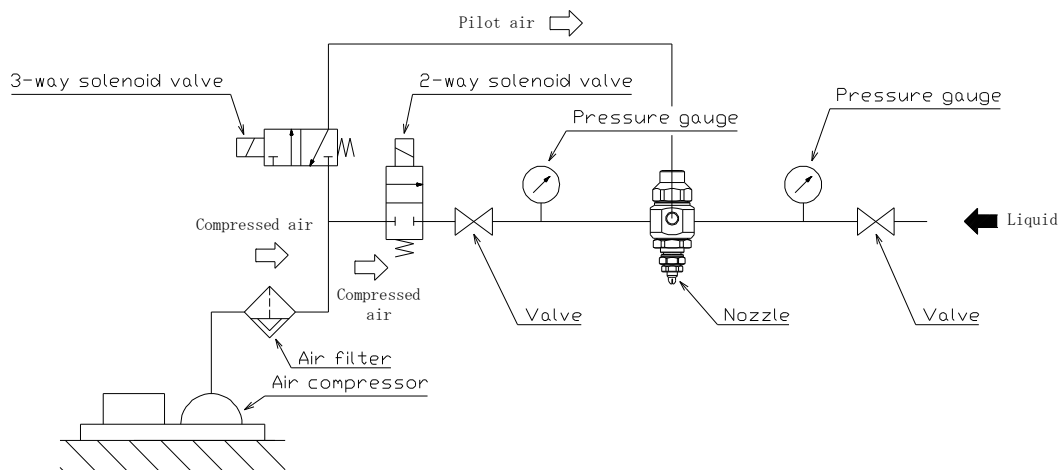

Fig. 1 Piping example using 3-way solenoid valve

Type SNB

When used with high liquid pressure, only stopping the compressed air will not lower the pressure enough to activate the shutoff piston, resulting in spraying only liquid.

To prevent this, use a 3-way solenoid valve for the air pipe.

If the pressure loss is too high due to the 3-way solenoid valve, use two 2-way solenoid valves with larger orifice diameters instead as shown below.

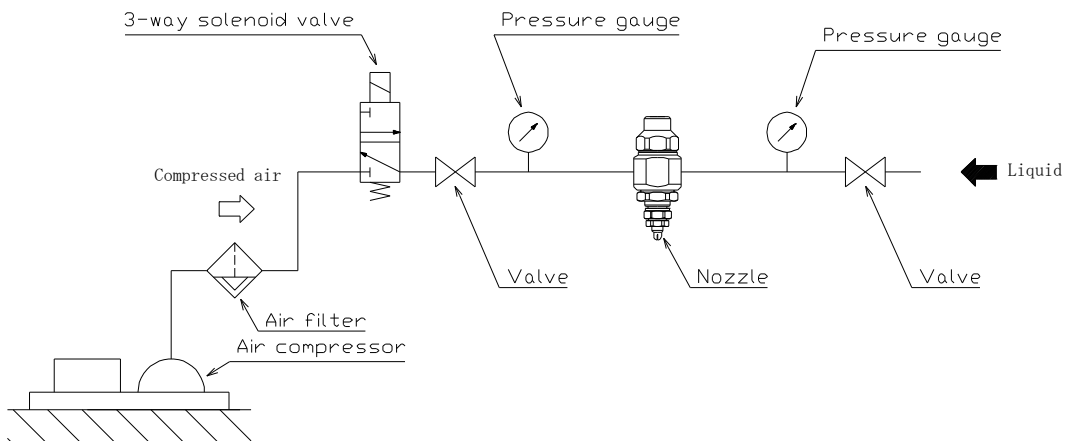

Fig. 2 Piping example using 3-way solenoid valve

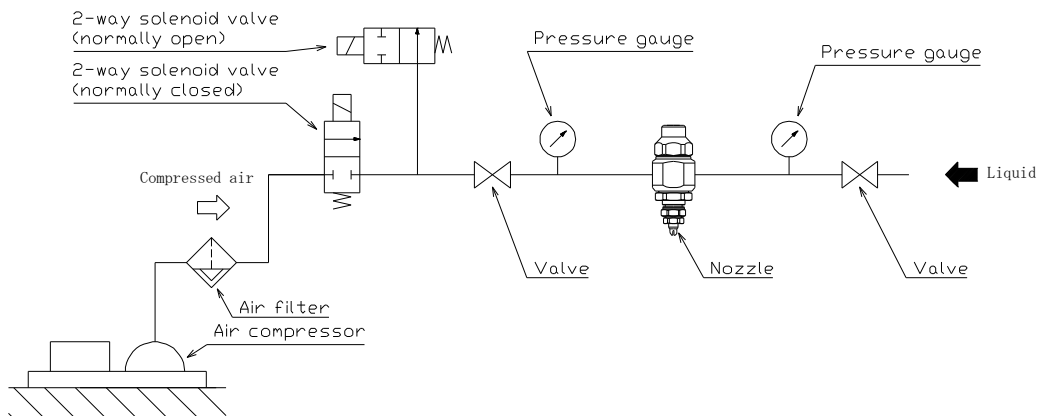
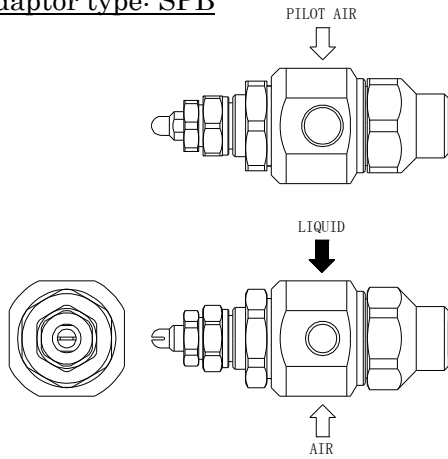

Fig. 3 Piping example using two 2-way solenoid valves

2. Components of Nozzle

(1) Nozzle Assembly

Adaptor type: SPB



Adaptor type: SNB

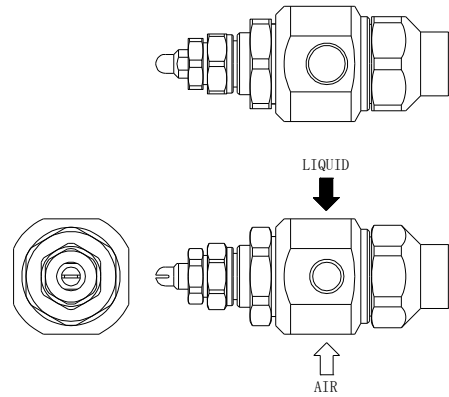

(2) Component Parts and Materials

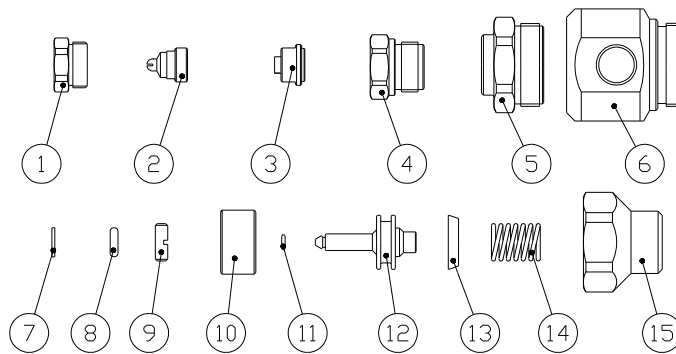

No.	Component	Material	Remark	No.	Component	Material	Remark
1	Cap	S303		9	Lock nut	S303	
2	Nozzle tip	S303	Consumable	10	Sleeve	PTFE	Consumable
3	Core	S303	Consumable	11	O-ring	FKM	Consumable
4	Nozzle adaptor	S303	Consumable	12	Piston	S303	
5	Connector	S303		13	Y-packing	NBR	Consumable
6	Adaptor	S303		14	Spring	S304	
7	Backup ring	PTFE	Consumable	15	Spring cap	S303	
8	O-ring (P4)	FKM	Consumable				

Note: (1) Consumables

The lifetime of a nozzle varies depending on the operational conditions.

Replace consumable parts when corrosion or pitting corrosion of a nozzle tip or other parts is found and/or nozzle performance significantly deteriorates.

(2) Dimensions and materials may differ depending on part number of the nozzle.

(3) In our material code, "S" represents "stainless steel".

For example, S303 stands for stainless steel 303.

3. Disassembly

- (1) Hold the adaptor (part #6) in a milling vice and unscrew the spring cap (#15) with a spanner. Then take out the spring (#14), piston (#12), O-ring (#11), and Y-packing (#13).

Necessary tools: Milling vice, Spanner 22 mm

Recommended tightening torque: 40 N·m

Unscrew the lock nut (#9) with a flathead screwdriver and remove the O-ring P4 (#8) and backup ring (#7).

Necessary tool: Flathead screwdriver

Note: If any of backup ring (#7), O-ring P4 (#8), O-ring (#11), and Y-packing (#13) is damaged, replace it with a new one.

- (2) 1. Hold the adaptor (#6) in a milling vice and unscrew the connector (#5) with a spanner.
2. Hold the connector (#5) in a milling vice and loosen the cap (#1) with a spanner (DO NOT remove the cap yet).
3. Use a hexagon socket wrench to remove the nozzle adaptor (#4).
4. Remove the cap (#1), then take out the nozzle tip (#2) and core (#3).

Necessary tools:

Milling vice, Spanner, Hexagon socket wrench

(See Table 1 below)

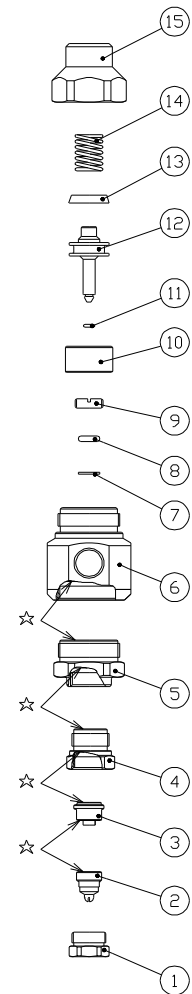

Table 1. Required tool size and tightening torque

Part	Air Consumption Code of BIM Series Nozzles		Necessary tool
	02, 04, 075	15, 22	
(#1) Cap	12 mm (15 N·m)	17 mm (25 N·m)	Spanner
(#4) Nozzle Adaptor	14 mm (30 N·m)	19 mm (40 N·m)	Hexagon socket wrench
(#5) Connector	21 mm (40 N·m)	21 mm (40 N·m)	Spanner

Recommended tightening torques are given in parentheses.

Note:

- (1) Make sure not to drop, damage or lose any of the small parts.
- (2) Nozzle adaptor (#4) is thin and fragile. To disassemble, first LOOSEN but DO NOT REMOVE the cap (#3), and remove the nozzle adaptor (#4) with a hexagon socket wrench. DO NOT use a spanner to remove the nozzle adaptor (#4).

4. Cleaning

After the disassembly inspect each part for damages of any kind.

Sealing parts include O-ring P4 (#8), O-ring (#11), and Y-packing (#13).

Any damage or surface scratches on these parts may cause the nozzle to malfunction.

Remove any dirt on the surface with a soft cloth.

Using a brush, carefully remove dirt and debris from the other metal parts. Take special care not to scratch or damage the nozzle orifice when cleaning the nozzle tip.

(1) How to clean the inside of the nozzle

- a. Impurities are most likely to adhere to the air orifice of the nozzle adaptor (#4). Pay special attention to check the condition of this part.
- b. If you find any dust or debris in the orifice, carefully remove them with a brush, toothpick, or bamboo skewer. Clean the inside of each part thoroughly from any dirt and debris to maintain performance

5. Assembly

Assemble in the reverse order of the 3. Disassembly on the previous page.

First, assemble the nozzle tip (#2), core (#3), cap (#1) and nozzle adaptor (#4) lightly, then attach the connector (#5). Use a hexagon socket wrench. DO NOT use a spanner as it may damage the nozzle adaptor (#4).

Note:

- (1) Before assembly, confirm that the sealing surfaces indicated with ☆ on the previous page and the orifice are clean and undamaged
- (2) Pay attention to the orientation of the Y-packing (#13) when installing it to the piston (#12). Fit the Y-packing with the groove side facing the tip of the piston as shown in Fig. 4.

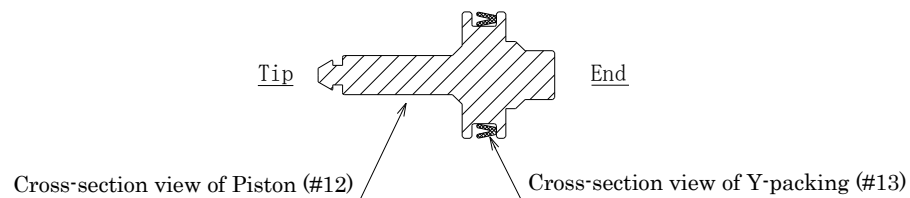

Fig. 4 Correct orientation of Y-packing

6. Maintenance

Check	Item	Check points
Daily	Spray	Visually check the spray pattern. If the nozzles are inside the equipment and cannot be seen, confirm that the spray pressure is normal.
	Pressure gauges and flow meters	Confirm that the air and liquid pressures and flow rate are correct during operation.
Periodically	Spray	Visually check the spray pattern.
	Appearance	Confirm that there is no corrosion or dust adhesion to the nozzle tip and orifice.
	Connection	Confirm that the cap, nozzle adaptor, connector, adaptor, and spring cap are tightened properly.

7. Troubleshooting

Troubles	Probable causes		Solutions
No spray is being created	Control	<ul style="list-style-type: none"> • Controller is not switched on. • Valves are not opened. 	<ul style="list-style-type: none"> • Switch it on. • Open the valves.
	Nozzle	<ul style="list-style-type: none"> • Nozzle or pipe is clogged. • Nozzle or pipe is clogged due to damage. • Liquid orifice and/or air orifice is clogged. • Piston does not work. 	<ul style="list-style-type: none"> • Check and clean the nozzle and pipe. • Replace the damaged part. • Clean them. • For SPB type, increase the pilot air pressure to 0.2 MPa or higher. • If increasing the compressed air pressure does not yield any results, replace the pipe and solenoid valve with larger ones to ensure an adequate air supply. • Replace the worn-out Y-packing.
Liquid leaks from the nozzle tip	<ul style="list-style-type: none"> • Dust/foreign particles adhered to the piston and/or sealing surfaces. • Damage or wear on the piston, O-ring, or the sealing surfaces. • Spring is missing. 		<ul style="list-style-type: none"> • Disassemble and clean the inside of nozzle. • Replace the parts. • Set the spring.
Air leaks	<ul style="list-style-type: none"> • Some parts are loose or not tightened. 		<ul style="list-style-type: none"> • Tighten the connections.
Liquid leaks	<ul style="list-style-type: none"> • Nozzle or pipe is cracked. • Nozzle or pipe is corroded. 		<ul style="list-style-type: none"> • Replace the cracked part. • Replace the corroded part.
Intermittent spray	<ul style="list-style-type: none"> • Seal failure between the nozzle tip, core, and adaptor (air or liquid leaks due to dust/foreign particles adhered or damage on the surface indicated with ☆ on page 6). • Either air pressure is too high or liquid pressure is too low. • Seal failure between the nozzle adaptor, connector, and adaptor. • Seal failure between the piston and O-ring. 		<ul style="list-style-type: none"> • Clean the sealing surface and replace the part. • Adjust the pressures. • Disassemble and clean the parts before re-assembly. • Disassemble and clean the parts before re-assembly.
Irregular spray pattern	<ul style="list-style-type: none"> • Nozzle or pipe is clogged. • Nozzle tip is deformed. • Nozzle tip is corroded. • Dust or foreign particles adhered on the orifices. 		<ul style="list-style-type: none"> • Check and clean the nozzle and pipe. • Replace the deformed part. • Replace the corroded part. • Clean the part.

8. Disposal

Disposal should be practiced according to the regulations and codes of local authorities, or ask a disposal professional.

9. Inquiries

For spare parts or any trouble, contact your supplier or the following:

H. IKEUCHI & CO., LTD.

Daiichi Kyogyo Bldg., 1-15-15, Awaza, Nishi-ku,

Osaka 550-0011 JAPAN

Tel: +81-6-6538-4015 Fax: +81-6-6538-4022

Email: overseas@kirinoikeuchi.co.jp

<https://www.kirinoikeuchi.co.jp/eng/>