

# 均等扇形ノズル / 高圧形

VNP

形  
庫

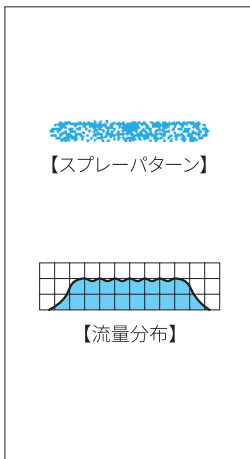

## 特長

- スプレーパターン全域にわたり均等な流量分布の扇形噴霧を発生。
- 高圧洗浄用に設計したR1/8・R1/4サイズ。

## 標準圧力

3MPa

## 主用途

高圧洗浄：自動車、車輛、コンテナ、タンク、製紙用フェルト、ワイヤーシリンダー、フィルタープレス、その他工業洗浄や脱脂

## 構造と材質と質量

構造	●ノズル本体の噴口部にセラミックを使用した一体形ノズル。
材質	●セラミック噴口部の他は、S303またはB(真ちゅう) オプション材質 S316
質量	●R1/8 S303:7g B(真ちゅう):7.4g ●R1/4 S303:20g B(真ちゅう):22g

注) 形番、材質により、外観・外形寸法が若干異なる場合があります。

## 外形図

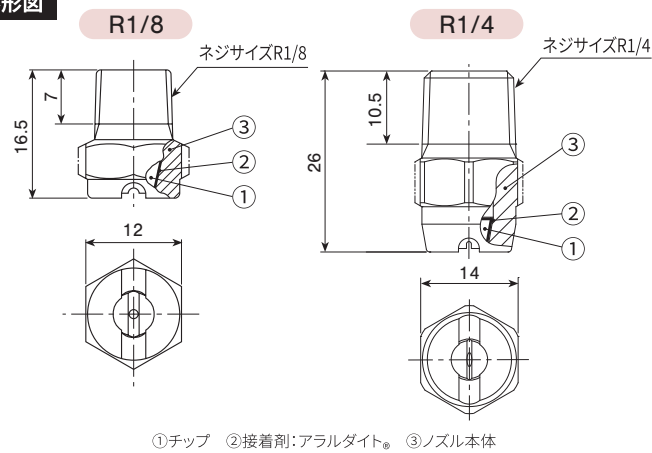

## 仕様

噴角の区分	噴量の区分	ネジサイズ		噴角(°)			噴量(ℓ/min)												異物通過径(mm)
		R1/8	R1/4	1 MPa	3 MPa	5 MPa	1 MPa	2 MPa	2.5 MPa	3 MPa	3.5 MPa	4 MPa	4.5 MPa	5 MPa	6.5 MPa	8 MPa	10 MPa	15 MPa	
65	43	○	○	60	65	65	2.50	3.54	3.96	4.33	4.68	5.00	5.30	5.59	6.37	7.06	7.91	9.67	0.7
	49	○	○	60	65	65	2.86	4.04	4.52	4.94	5.34	5.71	6.06	6.38	7.28	8.07	9.04	11.1	0.8
	56	○	○	60	65	65	3.22	4.54	5.08	5.56	6.01	6.42	6.81	7.18	8.19	9.08	10.2	12.4	0.9
	62	○	○	60	65	65	3.57	5.05	5.65	6.18	6.68	7.14	7.57	7.98	9.10	10.1	11.3	13.8	0.9
	68	○	○	60	65	65	3.93	5.55	6.21	6.80	7.35	7.85	8.33	8.79	10.0	11.1	12.4	15.2	1.0
	74	○	○	60	65	65	4.29	6.06	6.78	7.42	8.01	8.56	9.09	9.58	10.9	12.1	13.6	16.6	1.0
	80	○	○	60	65	65	4.65	6.56	7.35	8.04	8.68	9.28	9.85	10.4	11.8	13.1	14.7	18.0	1.0
	87	○	○	60	65	65	5.00	7.07	7.91	8.66	9.35	10.0	10.6	11.2	12.8	14.1	15.8	19.4	1.1
	99	○	○	60	65	65	5.72	8.08	9.04	9.89	10.7	11.4	12.1	12.8	14.6	16.2	18.1	22.1	1.1
	124	○	○	60	65	65	7.15	10.1	11.3	12.4	13.4	14.3	15.2	16.0	18.2	20.2	22.6	27.7	1.3
40	25	○	○	35	40	40	1.43	2.02	2.25	2.47	2.67	2.85	3.03	3.19	3.64	4.03	4.51	5.52	0.6
	31	○	○	35	40	40	1.78	2.52	2.82	3.09	3.34	3.57	3.78	3.99	4.55	5.05	5.64	6.91	0.7
	37	○	○	35	40	40	2.14	3.03	3.39	3.71	4.01	4.28	4.54	4.79	5.46	6.06	6.77	8.30	0.7
	43	○	○	35	40	40	2.50	3.54	3.96	4.33	4.68	5.00	5.30	5.59	6.37	7.06	7.91	9.67	0.8
	49	○	○	35	40	40	2.86	4.04	4.52	4.94	5.34	5.71	6.06	6.38	7.28	8.07	9.04	11.1	1.0
	56	○	○	35	40	40	3.22	4.54	5.08	5.56	6.01	6.42	6.81	7.18	8.19	9.08	10.2	12.4	1.0
	62	○	○	35	40	40	3.57	5.05	5.65	6.18	6.68	7.14	7.57	7.98	9.10	10.1	11.3	13.8	1.1
	68	○	○	35	40	40	3.93	5.55	6.21	6.80	7.35	7.85	8.33	8.79	10.0	11.1	12.4	15.2	1.1
	74	○	○	35	40	40	4.29	6.06	6.78	7.42	8.01	8.56	9.09	9.58	10.9	12.1	13.6	16.6	1.1
	80	○	○	35	40	40	4.65	6.56	7.35	8.04	8.68	9.28	9.85	10.4	11.8	13.1	14.7	18.0	1.2
30	25	○	○	26	30	30	1.43	2.02	2.25	2.47	2.67	2.85	3.03	3.19	3.64	4.03	4.51	5.52	0.6
	31	○	○	26	30	30	1.78	2.52	2.82	3.09	3.34	3.57	3.78	3.99	4.55	5.05	5.64	6.91	0.7
	37	○	○	26	30	30	2.14	3.03	3.39	3.71	4.01	4.28	4.54	4.79	5.46	6.06	6.77	8.30	0.8
	43	○	○	26	30	30	2.50	3.54	3.96	4.33	4.68	5.00	5.30	5.59	6.37	7.06	7.91	9.67	0.9
	49	○	○	26	30	30	2.86	4.04	4.52	4.94	5.34	5.71	6.06	6.38	7.28	8.07	9.04	11.1	1.0
	56	○	○	26	30	30	3.22	4.54	5.08	5.56	6.01	6.42	6.81	7.18	8.19	9.08	10.2	12.4	1.1
	62	○	○	26	30	30	3.57	5.05	5.65	6.18	6.68	7.14	7.57	7.98	9.10	10.1	11.3	13.8	1.1
	68	○	○	26	30	30	3.93	5.55	6.21	6.80	7.35	7.85	8.33	8.79	10.0	11.1	12.4	15.2	1.1
	74	○	○	26	30	30	4.29	6.06	6.78	7.42	8.01	8.56	9.09	9.58	10.9	12.1	13.6	16.6	1.2
	80	○	○	26	30	30	4.65	6.56	7.35	8.04	8.68	9.28	9.85	10.4	11.8	13.1	14.7	18.0	1.3
30	87	○	○	26	30	30	5.00	7.07	7.91	8.66	9.35	10.0	10.6	11.2	12.8	14.1	15.8	19.4	1.3
	99	○	○	26	30	30	5.72	8.08	9.04	9.89	10.7	11.4	12.1	12.8	14.6	16.2	18.1	22.1	1.5
	124	○	○	26	30	30	7.15	10.1	11.3	12.4	13.4	14.3	15.2	16.0	18.2	20.2	22.6	27.7	1.7

噴角の区分	噴量の区分	ネジサイズ		噴角 (°)			噴量 (ℓ/min)												異物通過径 (mm)
		R1/8	R1/4	1 MPa	3 MPa	5 MPa	1 MPa	2 MPa	2.5 MPa	3 MPa	3.5 MPa	4 MPa	4.5 MPa	5 MPa	6.5 MPa	8 MPa	10 MPa	15 MPa	
25	25	○	○	22	25	25	1.43	2.02	2.25	2.47	2.67	2.85	3.03	3.19	3.64	4.03	4.51	5.52	0.7
	31	○	○	22	25	25	1.78	2.52	2.82	3.09	3.34	3.57	3.78	3.99	4.55	5.05	5.64	6.91	0.7
	37	○	○	22	25	25	2.14	3.03	3.39	3.71	4.01	4.28	4.54	4.79	5.46	6.06	6.77	8.30	0.8
	43	○	○	22	25	25	2.50	3.54	3.96	4.33	4.68	5.00	5.30	5.59	6.37	7.06	7.91	9.67	0.9
	49	○	○	22	25	25	2.86	4.04	4.52	4.94	5.34	5.71	6.06	6.38	7.28	8.07	9.04	11.1	1.0
	56	○	○	22	25	25	3.22	4.54	5.08	5.56	6.01	6.42	6.81	7.18	8.19	9.08	10.2	12.4	1.1
	62	○	○	22	25	25	3.57	5.05	5.65	6.18	6.68	7.14	7.57	7.98	9.10	10.1	11.3	13.8	1.1
	68	○	○	22	25	25	3.93	5.55	6.21	6.80	7.35	7.85	8.33	8.79	10.0	11.1	12.4	15.2	1.2
	74	○	○	22	25	25	4.29	6.06	6.78	7.42	8.01	8.56	9.09	9.58	10.9	12.1	13.6	16.6	1.3
	80	○	○	22	25	25	4.65	6.56	7.35	8.04	8.68	9.28	9.85	10.4	11.8	13.1	14.7	18.0	1.3
	87	○	○	22	25	25	5.00	7.07	7.91	8.66	9.35	10.0	10.6	11.2	12.8	14.1	15.8	19.4	1.4
	99	○	○	22	25	25	5.72	8.08	9.04	9.89	10.7	11.4	12.1	12.8	14.6	16.2	18.1	22.1	1.5
	124	○	○	22	25	25	7.15	10.1	11.3	12.4	13.4	14.3	15.2	16.0	18.2	20.2	22.6	27.7	1.7
	15	25	○	○	12	15	15	1.43	2.02	2.25	2.47	2.67	2.85	3.03	3.19	3.64	4.03	4.51	5.52
31		○	○	12	15	15	1.78	2.52	2.82	3.09	3.34	3.57	3.78	3.99	4.55	5.05	5.64	6.91	0.8
37		○	○	12	15	15	2.14	3.03	3.39	3.71	4.01	4.28	4.54	4.79	5.46	6.06	6.77	8.30	0.9
43		○	○	12	15	15	2.50	3.54	3.96	4.33	4.68	5.00	5.30	5.59	6.37	7.06	7.91	9.67	1.0
49		○	○	12	15	15	2.86	4.04	4.52	4.94	5.34	5.71	6.06	6.38	7.28	8.07	9.04	11.1	1.1
56		○	○	12	15	15	3.22	4.54	5.08	5.56	6.01	6.42	6.81	7.18	8.19	9.08	10.2	12.4	1.1
62		○	○	12	15	15	3.57	5.05	5.65	6.18	6.68	7.14	7.57	7.98	9.10	10.1	11.3	13.8	1.2
68		○	○	12	15	15	3.93	5.55	6.21	6.80	7.35	7.85	8.33	8.79	10.1	11.1	12.4	15.2	1.3
74		○	○	12	15	15	4.29	6.06	6.78	7.42	8.01	8.56	9.09	9.58	10.9	12.1	13.6	16.6	1.3
80		○	○	12	15	15	4.65	6.56	7.35	8.04	8.68	9.28	9.85	10.4	11.8	13.1	14.7	18.0	1.4
87		○	○	12	15	15	5.00	7.07	7.91	8.66	9.35	10.0	10.6	11.2	12.8	14.1	15.8	19.4	1.5
93		○	○	12	15	15	5.36	7.58	8.48	9.28	10.0	10.7	11.4	12.0	13.7	15.2	17.0	20.8	1.5
99		○	○	12	15	15	5.72	8.08	9.04	9.89	10.7	11.4	12.1	12.8	14.6	16.2	18.1	22.1	1.6
111		○	○	12	15	15	6.43	9.09	10.2	11.1	12.0	12.9	13.6	14.4	16.4	18.2	20.3	24.9	1.6
124	○	○	12	15	15	7.15	10.1	11.3	12.4	13.4	14.3	15.2	16.0	18.2	20.2	22.6	27.7	1.7	

お引合い要領

形番はチャートをご覧いただき、下記のようにお伝えください。

〈例〉…1/8M VNP 6543 S303

<b>1/8M</b>	<b>VNP</b>	<b>65</b>	<b>43</b>	<b>S303</b>
ネジサイズ*1		噴角の区分*2	噴量の区分	材質
■ 1/8M ■ 1/4M		■ 65 ? ■ 15	■ 25 ? ■ 124	■ S303 ■ B

\*1 弊社の形番ではネジサイズの (R) はMと表記いたします。

\*2 形番によりノズルチップの色が異なります。噴霧角度の区分が25と15のうち噴霧流量が43~124の場合は形番の材質部分を「AL99 - (材質)」としてください。

〈例〉…1/8M VNP 2543 AL99-S303